

MEMORANDUM

McMILLEN, LLC

To:	San Francisco Bay Regional Water Quality Control Board	Project:	Design/Build of Ponds A16 and A17 on the Don Edwards San Francisco Bay NWR
Prepared by:	Greg Allington (McMillen)	Cc:	Jim Burby (USFWS) Eric Mruz (USFWS) Mendel Stewart (USFWS) Melissa Helton (USFWS) John Bourgeois (CSCC) Dan Axness, PE (McMillen)
Approved by:	Mort McMillen, PE (McMillen)		
Date:	September 9, 2011	Contract No:	F11PD00552
Subject:	Alviso Pond A16-A17 Restoration Design Modification Implications to Existing Environmental Permits		

1.0 INTRODUCTION

McMillen, LLC (McMillen) was contracted by the United States Fish and Wildlife Service (USFWS) to perform design-build services for the Don Edwards National Wildlife Refuge Alviso Pond A16-A17 Restoration. The project is currently in the design phase and design modifications have been made from the conceptual design that was approved in the existing environmental permits.

1.1 Purpose

The purpose of this memorandum is to compare the McMillen modified design against the conceptual design that was considered for the exiting permit approvals. Based on these modifications, the environmental regulatory agencies and USFWS must determine the implications to the existing permit approvals and decide upon the next steps in order for the project to proceed to the construction phase estimated to start in the Fall of 2011.

1.2 Scope

McMillen's scope of work for the design phase of the project includes preparing construction ready design documents and assisting USFWS with environmental permit supplements/addendums (if necessary). The scope of work for the construction phase includes constructing the project according to the construction ready design documents and performing biological surveys of the project area for sensitive species during construction.

1.3 Background

The original conceptual design drawings that were used in the original permit applications were prepared by ESA PWA and H.T. Harvey & Associates. These conceptual drawings were created to identify the overall goal of the Pond A16-A17 Restoration project. McMillen was contracted by USFWS to advance the conceptual design drawings to construction ready design documents. During this initial portion of the design phase, McMillen identified design modifications to achieve a better value for nesting island placement, water control in Pond A16 and create more suitable shallow water habitat. This memorandum

describes the modifications to the conceptual design and deviations from the existing permit approvals as well as details McMillen's approach to construct the project starting in the Fall of 2011.

2.0 EXISTING ENVIRONMENTAL PERMITS

McMillen performed a review of the existing environmental permits that have been formally approved for the project. This permit documentation was obtained from the USFWS and the South Bay Salt Pond Restoration Project website (<http://www.southbayrestoration.org/documents/>). The following lists the permit applications and approvals that were identified:

- California Regional Water Quality Control Board (RWQCB) San Francisco Bay Region 401 Water Quality Certification - Order No. R2-2008-0078 Date Issued: August 13, 2008;
- National Marine Fisheries Service (NMFS) Biological Opinion - 2007/08128 and 2008/02283 Date Issued: January 14, 2009. USACE Permit Enclosure 1;
- NMFS Essential Fish Habitat (EFH) Biological Opinion - 2007/08128 and 2008/02283 Date Issued: January 14, 2009. USACE Permit Enclosure 2;
- San Francisco Bay Conservation and Development Commission (BCDC) - Amendment No. Five to BCDC Consistency Determination No. CN 10-03 Date Issued: October 17, 2008; and
- United States Army Corps of Engineers (USACE) 404 Permit - Permit 27703S Date Issued: January 23, 2009;
- United States Fish and Wildlife Service (USFWS) Biological Opinion - 81420-08-F-0621 Date Issued: August 12, 2008. USACE Permit Enclosure 4;
- USFWS Final Environmental Impact Statement Record of Decision Date Issued: January 27, 2009.
- EDAW, Philip Williams and Associates, Ltd., H.T. Harvey and Associates, Brown and Caldwell, and Geomatrix. 2007b. South Bay Salt Pond Restoration Project Final Environmental Impact Statement/Report Volume 1. Submitted to USFWS and CDFG. December 2007.

2.1 Environmental Permit Contacts

The following is a list of the environmental permit contacts that this memorandum was sent to for a review:

- CDFG
 - Eric Larson
- California RWQCB San Francisco Bay Region
 - Andree Breaux Greenberg
- Environmental Protection Agency
 - Luisa Valiela
- NMFS
 - Gary Stern
- San Francisco BCDC
 - Max Delaney
- USACE 404 Permit
 - Paula Gill
- USFWS
 - Joseph Terry

3.0 MCMILLEN DESIGN DESCRIPTION

McMillen's design took into consideration the conceptual design prepared for the original permit applications and incorporated some of those design elements. However, modifications have been made to the conceptual design outlined in the RWQCB Order No. R2-2008-0078 (Order) Attachment A Figure 5 and this section summarizes the McMillen design and describes the discrepancies from the Order. In general, the redesign of Pond A16-A17 has decreased the number of structures and levees required to operate and maintain a fixed water surface elevation, which will reduce the overall cut and fill required for the new design and reduce the impacts to the surrounding environment. Detailed quantities and areas for project impacts and gains are located in Section 3.19. In fact, the redesign will provide 131 acres of additional tidal marsh habitat in Pond A17, creating additional benefits for tidal marsh species consistent with the SBSPRP goals. The conceptual design drawing that was approved under the existing permits is located in Attachment A and McMillen's design drawings are located in Attachment B that depicts the revised layout of the project.

In order for construction to begin in the Fall of 2011, McMillen is proposing to break the project into two stages. Stage 1 would consist of implementing the design elements that meet the existing permit approvals. Stage 2 would consist of design elements that are a variance from the existing permit approvals and may require re-initiation of the permitting process. The design elements in the following sections have been broken into Stage 1 and 2 construction elements and the specific project actions are described in detail. Section 4.1 outlines the overall construction approach and lists which construction element will be built in Stage 1 or 2.

The RWQCB issued the Order to perform restoration of Ponds A16-A17. The USFWS will follow the requirements outlined in this Order for construction and post-construction related activities unless a deviation from these requirements is explicitly outlined in this memorandum. Monitoring of the projects success will be performed as outlined on pages 39-43 (Provisions 1-19) and Attachment C of the Order.

3.1 Nesting Islands

3.1.1 Design Description

The following specific design criteria were used for the nesting islands:

- Spacing
 - No islands located within 300 feet from outboard levees.
 - No islands located within 100 feet from internal berms.
 - No islands located within 600 feet from proposed platforms.
 - No islands located within 100 feet from another island.
- 16 Islands (8 Circular and 8 Linear) in Pond A16.
 - Island crest height four feet above the average water level (3.2 feet NAVD) in managed Pond A16.
 - Two island shapes (linear and circular), each with a surface area of approximately 15,000 square feet above the average water level.
 - Undulations in the leeward edge of the linear nesting island to partition the nesting area.
 - Windward slope of 5:1 or flatter.
 - 10-foot bench between deep borrow areas and the toe of new islands.
 - Borrow areas connected to historic channels where feasible.

Nesting islands would be constructed within Pond A16 to provide bird nesting habitat. Islands would be constructed of bay mud or dry imported fill material (meeting soil quality standards) during Stage 1 and

bay mud or dry fill material from the lowering of the existing A17 tidal levee adjacent to Coyote Creek and Artesian Slough during Stage 2. During Stage 1 the islands would be constructed using local bay mud from around the island or imported fill material. Local bay mud from around the island would be excavated and placed within the berm. This fill would be used to load the island foundation to accelerate settlement and would not reflect the shape of the final nesting island design. In addition, the local bay mud would be allowed to dry and become firmer (“heal”). The “healed” mud would be reshaped into the final island configuration during Stage 2 along with the addition of dry levee lowering material. The circular and linear islands would have a ridge on the windward side to protect nesting birds and the linear islands would have undulations on the leeward side. Islands have been located within Pond A16 based on the design criteria and the micro topography of the pond bottom for the least amount of pond bed disturbance.

The pond bed in Pond A16 ranges from 2.0 feet to 4.0 feet NAVD. The water surface level for Pond A16 would be set at the average water level of 3.2 feet NAVD. By setting the average water level at this elevation, it reduces the amount of material that is required to build the islands and creates suitable shorebird foraging habitat ranging from 2 to 12 inches in depth.

The sequence for the island construction would involve constructing the islands during Stage 1 with bay mud or imported fill material as approved in the existing permits. The islands would be built to an elevation of approximately between 5.0 and 7.0 feet NAVD in height. This material would be allowed to dry and then it would be reshaped during Stage 2 after the islands have settled. The nesting islands would be allowed to settle while other construction tasks (i.e.-A16 Outlet WCS and A16 Wildlife Viewing Platform) are being constructed during Stage 1. After other site restoration tasks are completed, the islands would be shaped to final design at an elevation of 7.8 feet NAVD and the Stage 2 levee lowering dry material or bay mud would be placed on the islands. The average island height would be overbuilt by 50% to account for additional settlement of the bay mud under the dry fill material.

3.1.2 Permit Review

The McMillen design approach proposes to construct 16 islands (8 circular and 8 linear) in Pond A16 during Stage 1 and 2 construction activities. The permit approvals state that 50 islands (25 circular and 25 linear) are to be constructed in Pond A16 as stated on page 11 (Finding 27) of the Order. The number of nesting islands was reduced based on the available amount of on-site material to construct the islands and the high cost associated with importing clean fill material. The proposed number of 16 nesting islands reflects the amount of available material located in the A17 levee and the Bay Mud located in Pond A16 in relation to a feasible cost to construct these islands. The McMillen design allows for additional nesting islands to be constructed in Pond A16 without constructing any other water control structures in the pond itself. Depending on future funding in subsequent phases of this project, the potential for up to 34 additional nesting island locations are available within Pond A16. The potential future islands would be constructed using local bay mud or imported fill material.

3.2 A17 Intake WCS Removal and Levee Lowering

3.2.1 Design Description

The following design criteria were used for the A17 intake WCS removal and levee lowering:

- Completely remove the existing A17 intake structure.
- Lower approximately 2,050 feet of A17 levee along Coyote Creek to approximately MHW or 7.0 feet NAVD.

- Lower approximately 5,000 feet of A17 levee along Artesian Slough to approximately MHW or 7.0 feet NAVD.
- Leave sporadic upland hummocks for escape cover for salt marsh harvest mice during high tide events every 200 feet in portions of the levee adjacent to suitable habitat.
- Lower approximately 2,260 feet of A17 levee along the southern boundary to 4.0 feet NAVD.

The removal of the existing A17 Intake WCS in Stage 2 would tidally connect Pond A17 with Coyote Creek, and over time (50 year goal) it would create pickleweed marsh habitat and restore the tidal hydraulic connection between Pond A17 and the adjacent sloughs. There are no plans to dredge the existing pilot channel or make it wider after the existing intake structure is removed. This channel is expected to stabilize itself over time. Salvageable material from the intake structure would be used in other restoration tasks and all unsalvageable material would be disposed off-site at an appropriate facility.

The dry material excavated from the lowered levees would be used to construct the nesting islands and levees during Stage 2. If excess material is available from the levee lowering, it will be placed into the adjacent borrow ditch. Lowering the levee to the existing adjacent marsh habitat would reduce erosion when tidal water flows through the marsh habitat into Pond A17. Sporadic hummocks above the high tide elevation would be left for escape cover for salt marsh harvest mice.

The A17 levee along the southern portion of A17 would also be lowered during Stage 2. This levee would be removed to an elevation of 4.0 feet NAVD to match the existing marsh habitat. New structural levees would be built from this material at the new A16 levee and at the new A16 intake WCS levee to separate Pond A16 from the new tidal habitat.

3.2.2 Permit Review

The levee breach and structure removal at the inlet of Pond A17 from Coyote Creek is not permitted under existing permit approvals. Permit approvals state that the existing structure is to remain in place with a new fish screen installed and there is no approval for a complete levee breach in any location in Pond A17. By breaching the existing intake structure, it eliminates the need for a second intake structure. As a result, there would be minimal impacts to the salt marsh habitat on the northern side of Pond A17 levee.

Lowering of the levee along the northern, eastern and southern portions of Pond A17 is not permitted under the existing permit approvals. Permit approvals state that the only source of water entering Pond A17 is through the new and existing intake structures that would both require fish screens. However, the 50-year goal for Pond A17 according to the selected alternative (Alternative C) shown on Figure 2-7b in the Final Environmental Impact Statement/Report is to restore it to tidal habitat (Figure 1). The permit approvals do not approve this levee breaching and lowering; however, the intended use does meet the criteria of the 50-year long-term objective for this project.

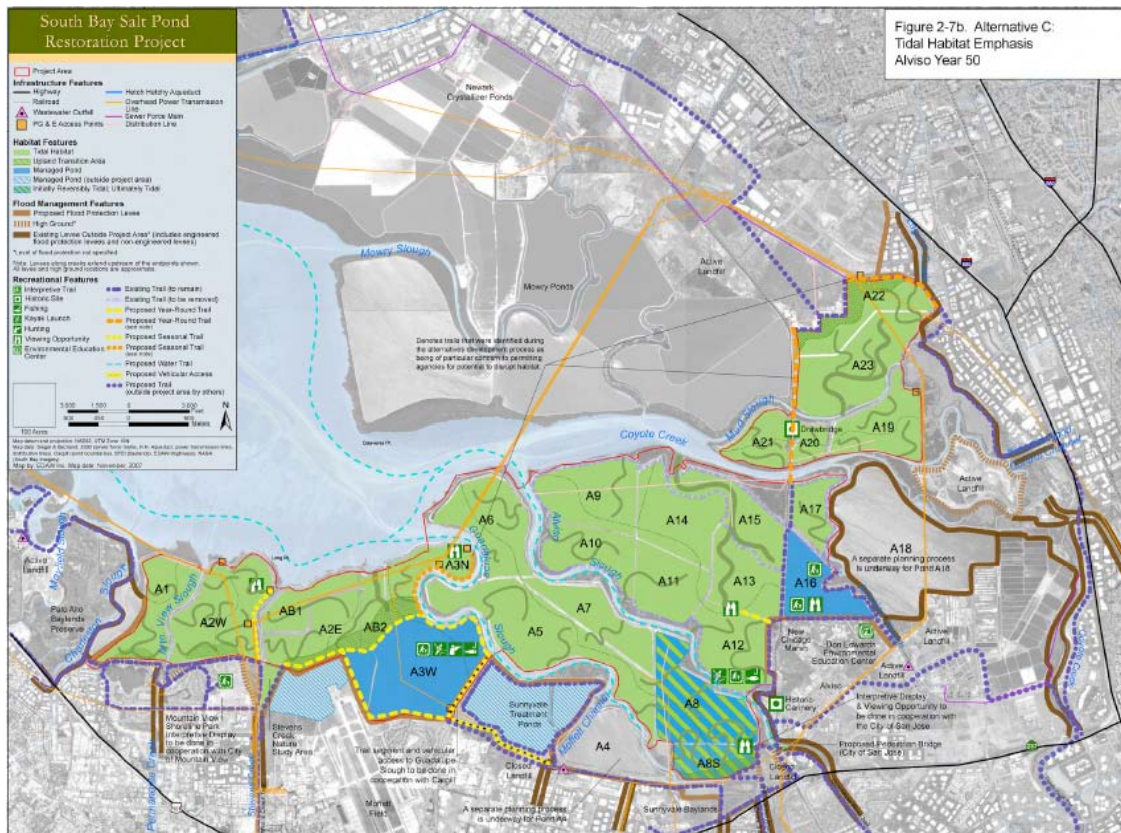

Figure 2-7b. Alternative C: Tidal Habitat Emphasis Alviso Year 50

Figure 1. 50-Year Long Term Goal for Pond A17

Once the existing A17 Intake WCS is removed and the A17 levee is lowered, tidal flows will enter Pond A17 unobstructed. A report prepared by the United States Geological Survey titled *Sediment Deposition and Erosion in South San Francisco Bay, California from 1956 to 2005* prepared in 2006 describes sedimentation in the vicinity of Pond A17. Based on the findings of this report, it is expected that sediment will continue to accumulate south of the Dumbarton Bridge. This new tidal water regime is expected to transport sediment into the pond area filling in the low elevation areas over time to match the existing marsh elevation of approximately MHW. In order to keep the west borrow ditch clear of sediment accumulation and facilitate the transport of water at lower elevations than the pond bed, a water control berm is proposed for the eastern borrow ditch and is described in detail in Section 3.9. Monitoring of Pond A17 sediment accumulation will be performed on a yearly basis as outlined in the *South Bay Salt Pond Restoration Project Phase 1 Monitoring Plan* prepared in 2008 which will include monitoring of the subtidal/open water habitat and intertidal mudflat areas. The monitoring will be compared against the Phase 1 adaptive management triggers and potential management actions to determine the success of the restoration.

Lowering the A17 levee will remove the existing flood control levee protecting Pond A16, surrounding ponds and the community of Alviso. The existing A16 levee that will be exposed to tidal fluctuations has the same levee structural stability as the proposed lowered A17 levee. The portions of the levee that presently have gaps (A16 Levee and A16 Intake WCS Levee) will be filled in to match the structural integrity of the adjacent levees. The new levee that will be exposed to tidal fluctuations will not increase the risk of flood impacts or levee failures above existing conditions at Ponds A16-A17. Attachment B Table B-8 Project Objective 2 of the Order states the restoration target is “No increase in tidal or fluvial flood risk at any project phase and improve tidal and fluvial flood protection in the South Bay in specific

areas". The adaptive management parameters, triggers and actions outlined in this table will be adhered to during the monitoring phase of the project. The McMillen design will meet Project Objective 2 and will not increase flood risk and will improve flood protection in the South Bay.

Since the levee lowering is not approved under existing permit approvals, McMillen is proposing to perform this construction element during Stage 2. Stage 2 would excavate the entire levee down to approximately MHW which would allow high tides to enter Pond A17. This construction action is not approved under existing permits.

Lowering the A17 levee to approximately MHW would remove all upland areas that would stay dry during high tide events. The salt marsh harvest mouse has not been documented to inhabit areas adjacent to the A17 levee; however, suitable habitat is present and harvest mice may be present. During high tide events that inundate the marsh habitat, harvest mice escape to dry ground. Sporadic upland hummocks (approximately 10 feet in diameter at the top and side slopes of 3:1) spaced approximately every 200 feet would be left on the levee to create this escape habitat for harvest mice during high tide events (Sheet 5). USFWS specialists have been consulted regarding the upland hummocks proposed for salt marsh harvest mouse escape habitat. Even though mice have not been documented in this area, the hummocks will provide suitable habitat for mice if they migrate into this area.

3.3 A16 Intake WCS

3.3.1 Design Description

The A16 Intake WCS design criterion consists of the following:

- Maximum capacity of 200 cfs.
- Top of the structure elevation 15.0 feet NAVD.
- Fish screens would sit inside of guide slots cast into the concrete walls with one-way flow only through the fish screens.
- 63-inch HDPE culvert with a flow line elevation of 0.0 feet NAVD.

The proposed location of the A16 Intake WCS is near the southwest corner of Pond A17 at the western end of the levee lowering. It would be used to screen and regulate flow into Pond A16. The intake structure would be built perpendicular to the borrow ditch allowing water and debris to flow past the structure reducing the possibility for excessive debris and sediment build-up. In addition, timber piles and a log boom would be constructed around the front of the intake structure to prevent large floating debris from damaging the fish screens.

Water will be conveyed from the A16 Intake WCS to Pond A16 via one 63-inch HDPE culvert (approximately 330 feet) located under the Intake WCS Levee. The intake culvert would have a tide gate to prevent water from flowing back into Pond A17. The capacity of the A16 intake culvert (approximately 200 cfs) would be greater than the fish screen capacity to pass flow so that water is unobstructed once it passes through the fish screen.

Sheet pile would be installed around the perimeter of the intake slab to act as a cofferdam during construction. After construction of the intake is complete, the sheet pile would be cutoff at the top of the concrete slab at the upstream end. A concrete slab would be supported by tie-back concrete walls and the intake structure walls would be cast on top of the concrete slab. This method of support was determined to a more stable and cost effective option for the proposed structure than the concrete piles based on the lack of cohesiveness in the bay mud. Fish screen guide slots would be cast into the floor and walls of the

structure to support three travelling belt fish screens. The travelling belt fish screens would consist of a continuous plastic screen driven in a continuous loop. Water would flow through the screen while debris including cattails, bulrush, and pickle weed would be carried over the screen and discharged into the intake flow control vault and discharged into Pond A16.

Porosity baffles would be installed behind the fish screens to control the flow through the structure. A maintenance platform would be installed on the top of the intake to allow maintenance access to the fish screens and porosity baffles.

3.3.2 Permit Review

The permitted A17 intake structure is located on the outboard levee between Pond A17 and Coyote Creek as stated on page 11 (Finding 27) of the Order. The relocation of this structure is not consistent with the permit approvals and also introduces new tidal habitat as discussed in Section 3.2. The relocation of this structure on the Pond A17 levee would eliminate impacts to the salt marsh habitat on the north side of Pond A17 levee where it was originally specified to be installed.

3.4 A16 Intake Fish Screen

3.4.1 Design Description

The fish screen design criteria consists of the following:

- Capacity greater than the intake structure at an approach velocity of 0.33 ft/sec regulated by porosity baffles;
- Through flow above about 3.2 feet NAVD;
- Three independent inclined traveling belt fish screens;
- Top of the fish screens at 12.2 feet NAVD;
- Fish screens would sit at the face of a concrete vault; and
- Flap/tide gates would allow one-way flow through fish screens.

The fish screen has been designed to meet the NMFS fish screen criteria for tidal areas. Three independent inclined traveling belt fish screens would be installed inside of the A16 intake water control structure. Its function is to prevent fish from entering Pond A16 and the fish screen would be operated year-round. The fish screens would be installed at an angle so that debris would be collected and carried over the fish screen and flow into Pond A16. The fish screen structure would be installed on the face of the intake vault upstream of the culvert. Porosity baffles would be installed behind the fish screen to adjust the volume of water flowing into Pond A16. The fish screen is manufactured by Intralox and is constructed of stainless steel and ultraviolet resistant Acetal plastic. Each screen is operated independently and powered by one, 2 horsepower (hp) motor.

3.4.2 Permit Review

The new intake structure would have three independent fish screens leading to one intake culvert. The A16 intake culvert would be screened year-round and no fish would be allowed to enter Pond A16 as stated on page 36 (Prohibition 4) of the Order. This water intake regime is consistent with the NMFS BO *Table 1 SBSP Water Intake Structures at Managed Ponds – Operational Measures to Protect Juvenile Salmon and Steelhead* on Page 9 which states that the intake from Coyote Creek to Pond A17 must have a fish screen installed during both the summer and winter months (year round).

3.5 A16 Outlet WCS

3.5.1 Design Description

The A16 Outlet WCS design criteria consists of the following:

- Discharge a maximum capacity of 180 cfs to Artesian Slough during low tide events.
- Prevent water from flowing back into Pond A16 through the outlet structure.

The proposed location for the A16 Outlet WCS is in the east levee near the south end of Pond A16. The existing outlet structure would be demolished and the new structure would be constructed in the same location. The flow control into the structure would be regulated by an overflow weir located within Pond A16. The crest of the weir would be constructed at elevation 3.0 feet NAVD with an adjustable overflow weir installed along the top of the wall to allow the weir elevation to be raised up to 4.0 feet NAVD. Two sluice gates would be installed at the bottom of the weir structure (0.0 feet NAVD) to allow additional drainage of Pond A16 if maintenance activities would require in the future.

A sluice gate would be installed on the upstream side of the water control structure to regulate flows. A tide gate would be located inside the water control structure to prevent water from entering back into Pond A16 from Artesian Slough. After flowing through the tide gate, the water would flow through a 4-foot tall by 8-foot wide concrete culvert beneath the Pond A16 levee. The flow would be discharged from the culvert into a pilot channel leading directly into Artesian Slough.

The outlet structure would be supported by a 12-inch concrete slab on a subgrade of gravel and geotextile. Concrete walls would be cast on top of the concrete floor.

3.5.2 Permit Review

A new outlet structure in Pond A16 levee to the south of the existing outlet structure has been approved by the permitting agencies. This permitted structure consists of six new 4-foot outlet culverts with combination slide/flap gates on both ends. The design proposes to install only one new large culvert in the same location as the existing outlet structure. By demolishing the existing culvert and constructing the new one in its place, impacts to the pond and surrounding salt marsh environment are significantly reduced.

3.6 A16 Outlet Pilot Channel

3.6.1 Design Description

The following design criteria were used for the A16 outlet pilot channel:

- Approximately 140 feet in length through salt marsh into Artesian Slough.
- Channel invert elevation would be -1.0 feet NAVD, which is approximately 1 foot below the invert of the outlet structure culverts (0.0 feet NAVD).
- Channel bottom width would be approximately 25 feet.
- Channel top width would be approximately 75 feet.
- Channel maximum side slopes of 3:1.

The existing pilot channel associated with the existing outlet structure would be deepened if necessary to meet the design criteria. The pilot channel would also be extended by excavating through the adjacent

salt marsh to extend the pilot channel directly into Artesian Slough. Material excavated from the pilot channel would be placed within the Pond A16 borrow ditch in the vicinity of the outlet structure.

3.6.2 Permit Review

The permits have approved a new pilot channel from the new A16 outlet structure directly into Artesian Slough. The permits anticipated a 50-foot long channel with 3:1 side slopes, 105-foot top width, 48-foot bottom width and the channel bottom would be 1-foot below the culvert invert. The McMillen design for the pilot channel does not meet permit approval requirements with the expansion of the pilot channel directly into Artesian Slough. However, impacts to the salt marsh from the construction of the second outlet structure have been eliminated as described in Section 3.5.

The salt marsh harvest mouse has not been identified in areas adjacent to the A16 outlet structure; however, suitable habitat is present and harvest mice may be present. Proper pre-construction mitigation efforts would be performed to reduce potential impacts.

3.7 A16 Levee

3.7.1 Design Description

The A16 Levee design criteria consists of the following:

- Located in the A16-A17 Canal near the southeast corner of Pond A17.
- Crest elevation set at 12.2 feet NAVD and width 12.0 feet.
- Side slope of 3:1 or match existing.

Fill material would be placed in the Pond A16-A17 canal to construct a new levee along the A16 levee approximately 150 feet in length. This new levee would be constructed out of dry A17 levee lowering material to 12.2 feet NAVD which will be the same elevation as the other levees. The dry fill material would be compacted using mechanical methods to reduce the amount of potential settlement.

3.7.2 Permit Review

The new A16 structural levee is located in the location of the conceptual design A16 intake structure. The permit approvals do not approve a new levee in this location. However, this levee is associated with larger design elements and helps to provide the overall goal of this project.

3.8 A16 Intake WCS Levee

3.8.1 Design Description

The A16 Intake WCS Levee design criteria consists of the following:

- Crest elevation at 12.2 feet NAVD and width of 20.0 feet.
- Side slope of 5:1.

A new structural levee would be constructed at the A16 intake structure into Pond A16 approximately 230 feet in length. The intake WCS culvert would be installed underneath this levee and the levee would connect into the existing Pond A16 and A17 levees. This levee would be constructed to a height of 12.2

feet NAVD to match the adjacent levees and would also serve as the new trail route. This levee would be constructed from the dry A17 levee lowering material and compacted to reduce settlement.

3.8.2 Permit Review

This new structural levee is located in the old sewer discharge ditch between Pond A16 and A17. The permit approvals do not approve a new levee in this location. However, this levee is associated with larger design elements and help to provide the overall goal of this project.

3.9 A17 Water Control Berm

3.9.1 Design Description

The A17 water control berm design criteria consists of the following:

- Crest elevation of 11.0 feet NAVD at the levee –sloping down to approximately 4.0 feet NAVD where the berm ties into the marsh surface.
- Side slope of 5:1.
- Final net fill height would be approximately 120% of finished grade.

A new water control berm would be constructed in the borrow ditch on the east side of Pond A17 approximately 400 feet in length. The elevation of this berm would be set at 11.0 feet NAVD at the levee and sloping down to approximately 4.0 NAVD feet at the marsh surface. The berm is intended to divert water through the western borrow ditch during incoming tidal flow. The diversion of water through the west borrow ditch would increase flow velocity and reduce the amount of sediment that would settle in the west borrow ditch. In addition, the berm is expected to enhance sediment settlement in the east borrow ditch by reducing flow velocities. This berm would be constructed from the dry A17 levee lowering material and mechanically compacted to reduce settlement.

3.9.2 Permit Review

This new structural berm is located in the borrow ditch in Pond A17. The permit approvals do not approve a new berm in this location. However, this berm is associated with larger design elements and helps to provide the overall goal of this project.

3.10 A17 Fishing Platform

3.10.1 Design Description

The following design criteria were used for the A17 fishing platform:

- Platform supported by 14-inch square precast concrete piles.
- Decking is a plastic and wood fiber composite.
- Guard rail is a custom wood and steel picket rail.
- The fishing platform would have a deck elevation approximately three feet above the top of the levee.

The A17 fishing platform would be located at the northwest corner of Pond A17 for fishing in Coyote Creek during medium to high tides. The platform would be extended to the end of the salt marsh along Coyote Creek and would have a boardwalk approximately 50 feet long leading up to it from the levee.

The platform would be elevated above the top of the levee approximately three feet with an ADA compliant ramp, seating and fishing areas. The platform would extend into Coyote Creek far enough to allow for safe and unobstructed fishing by the general public.

The platform would consist of galvanized steel framing supported by precast concrete piles. Wood floor joists at 16-inch on-center would be attached to the steel framing and would support the composite decking.

3.10.2 Permit Review

This fishing platform is located in a different location than the permit approvals but allows the general public to fish in Coyote Creek and view the Drawbridge historical site across Coyote Creek. The pilings will be made of concrete and will require the use of a pile driver to install. Proper sound attenuation techniques will be used during installations of the piles as stated on page 50 (Provision 48) of the Order.

3.11 A16 Wildlife Viewing Platform

3.11.1 Design Description

The following design criteria were used for the A16 wildlife viewing platform:

- Platform supported by 14-inch square precast concrete piles.
- Decking is a plastic and wood fiber composite.
- Guard rail is a custom wood and steel picket rail.

The A16 wildlife viewing platform would be located on the east side of Pond A16 for wildlife viewing. The platform would accommodate parties of up to 15 people. The levee would be raised in the area of the viewing platform so that the deck is approximately three feet above the majority of the levee and still be ADA accessible. The level of the platform deck would be the same height as the levee and there would be no ramp leading up to this platform.

The platform would consist of galvanized steel framing supported by precast concrete piles. Wood floor joists at 16-inch on-center would be attached to the steel framing and would support the composite decking.

3.11.2 Permit Review

This wildlife viewing platform is located in a different location than the permit approvals but will still be located within Pond A16 for wildlife viewing of the nesting islands. The pilings will be made of concrete and will require the use of a pile driver to install. Proper sound attenuation techniques will be used during installations of the piles as stated on page 50 (Provision 48) of the Order.

3.12 Interpretive Signage

3.12.1 Design Description

The following design criteria were used for the interpretive signage:

- Interpretive signage would be incorporated into both the fishing and viewing platforms.
 - Three kiosks consisting of signs (24-inches by 36-inches) mounted on each platform.

- Interpretive signage at the Environmental Education Center depicting maps of the new trail and ponds.
 - Two kiosks consisting of signs (36-inches by 60-inches).

Interpretive signage would be incorporated into the fishing and viewing platforms and would consist of kiosk mounting brackets and the kiosks themselves. Two new trail map kiosks would be installed at the EEC describing the new trail route along Pond A16 and A17. Information contained on these kiosks would be in both English and Spanish.

3.12.2 Permit Review

The interpretive stations are consistent with the permit approvals. An extra interpretive station has been added in the northwestern corner of Pond A17 to describe the historical landmark of Drawbridge across Coyote Creek. These stations would be located in the upland and on platforms and are not expected to violate any permit conditions.

3.13 Construction Access

3.13.1 Design Description

The following design criteria were used for construction access:

- Two possible land construction access points.
 - East side of Pond A16 via Southbay Highway 237, Zanker Rd, Los Esteros Rd, Grant Rd, and through the EEC; and
 - West side of Pond A16 via Southbay Highway 237, North 1st St., Liberty St., Catherine St, Hope St. and through the Alviso Marina County Park restricted access path.
 - Levees may require grading and widening.
 - Heavy vehicles would avoid crossing water control structures if the vehicle exceeds the weight bearing capacity of the structure.
- Staging Area
 - A portion of the staging area would be located on Ponds A16 and A17 levees. These levees may be enlarged using fill material for additional room.
 - An expanded staging area is proposed to the south of the EEC.

Only land access is anticipated for construction access to Ponds A16 and A17. East side access would be required for the new A16 water control structure. Material and equipment delivery traffic may congest the EEC and parking lot area, and could potentially be restricted in order to prevent damage to the existing roadway.

The West side access is preferable for most material and equipment deliveries due to the shorter haul distance on the levee access roads; however, there is concern with ability to use the private railroad crossing required to get from Marina County Park access road to the northwest corner of Pond A16. If the west side access is deemed necessary for construction access, McMillen will coordinate with the railroad owner for written authorization to cross the railroad line.

If equipment sizing appears too large for the levee or water control structures, design modifications to the levees and/or water control structures would need to be performed.

Water access is not anticipated at this time.

3.13.2 Permit Review

The permit approvals outline the east side construction access but not the west side. The west side access would not impact any critical aquatic features or habitat. BMP's would be used on the west side construction access if the appropriate written authorization is received from the railroad owner.

The staging area is proposed on the levees as well to the south of the EEC.

3.14 Cable Fence

3.14.1 Design Description

The following design criteria were used for the cable fence:

- Install 500 linear feet of permanent cable fence.
- Black vinyl clad stainless steel cable.

Permanent cable fencing would be installed to limit access around the fishing and viewing platforms.

3.14.2 Permit Review

The permit approvals do not discuss cable fence. The cable fence along the viewing platforms would deter the general public from walking under the structure. It is not intended as a security fence but should serve as a deterrent. It is not expected to violate any of the permit conditions.

3.15 Crushed Rock Trail Surfacing

3.15.1 Design Description

The following design criteria were used for the crushed rock trail surfacing:

- Install approximately 20,000 linear feet of ADA-compliant crushed aggregate.
 - Six inches deep by 12 feet wide.
 - Installed on top of geotextile.
 - Slope the trail towards Pond A16-A17 at 2.0%.
 - Firmness: The degree to which the surface resist deformation by indentation when a person walks or wheels across the surface (0.3 inches).
 - Stability: The degree to which the surface remains unchanged by a person walking or maneuvering a wheelchair (0.5 inches).
 - Slip resistance: Based on the frictional force necessary to permit a person to ambulate without slipping.

All of the levees surrounding Ponds A16-17 that are not lowered would be raised to 12.2 feet NAVD and surfaced with gravel.

3.15.2 Permit Review

None of the crushed rock trail surfacing would be installed in water and it appears to comply with permit approvals.

3.16 Water Pollution Control Plant's Pipeline

3.16.1 Design Description

The following design criteria were used for the sewer pipeline:

- Obtain necessary permits/approvals from the City of San Jose/Santa Clara prior to pipeline removal.
- Saw cut the abandoned sewer pipeline on both ends of the A16 outlet pilot channel.
- Plug both open ends of the pipeline with a suitable fill material.

The proposed Pond A16 outlet structure pilot channel would cross the San Jose/Santa Clara Water Pollution Control Plant's former concrete sewer pipeline. The pipeline is located along the south bank of Artesian Slough, within the 50-foot wide strip of salt marsh land owned by the City of San Jose. Removal of a section of this pipeline is proposed so that the pipe does not impede drainage from the outlet structure or become a hazard.

3.16.2 Permit Review

McMillen will work with USFWS and the City of San Jose/Santa Clara to obtain the required easements and authorizations to demolish this pipeline.

3.17 Hydraulics

3.17.1 Design Description

The following design criteria were used for hydraulic design:

- Managed cell water depths.
 - Average depth approximately 2 to 8 inches (range no greater than 2- to 12-inches) around nesting islands, preferably at the lower end of the range.
 - The minimum target water level at the average depth of 2 to 6 inches is approximately 3.2 feet NAVD.
 - The design should allow flexibility to adaptively increase the area of very shallow water habitat, as needed, via adjustment of the water control structures.
- Increase flows and decrease hydraulic residence times in Pond A16 compared to existing conditions to provide adequate flushing for bird habitat and water quality objectives during the summer season.
- Allow for full tidal exchange in Pond A17 to promote improved water quality.
- Prevent salmonid entrapment in Pond A16 year-round by using fish screens.
- Limit the level of effort required for the operation and maintenance during normal operations.
- Account for a storm surge or sea-level rise to increasing Bay tide levels by 16 inches (1.3 feet) relative to the baseline conditions.

Pond A16 would be managed hydraulically to meet the above stated design criteria for shallow water habitat. A large majority of Pond A16 bed has elevations ranging from 2.2 to 3.1 feet NAVD.

The breaching of A17 levee will allow uninhibited tidal fluctuations to occur in Pond A17 and hydraulic residence times will fluctuate with the tide cycle. Pond A16 will be controlled by the A16 Intake and Outlet WCS's. Table 1 lists the McMillen design estimated hydraulic residence time for Ponds A16

during the year. These residence times are also compared against the times outlined in Finding 45 Table 8 of the Order. The flows listed in the table will be consistent year-round from the implementation of the fish screen and WCS's. Flows into and out of Pond A16 can be increased, decreased or completely shut off at the user's discretion by adjusting slide gates. Pond A17 will be flushed with the tide cycle on a regular basis and the retention time for Pond A17 was not analyzed.

Table 1. Pond A16 Hydraulic Residence Time

Pond	Area (acres)	Depth (ft)	Volume (acre-ft)	Outlet Flow (ft ^{3/s})	Residence Time (days)
A16-McMillen Design	243	1.68	408	60 (average flow)	3.4
A16-Order	243	1.7	413.1	24	8.7

With the restoration of Pond A17 to tidal habitat, this eliminates hydraulic residence time in Pond A17. The Order estimated that hydraulic residence time in Pond A17 was 3.3 days for a total of 12 days between both Ponds A16 and A17. The McMillen design would have water residing in Pond A16 for 3.4 days which results in a reduction of 8.6 days.

3.17.2 Permit Review

The hydraulics outlined in the McMillen design do not meet permit approvals in relation to the new tidal restoration in north Pond A17. These items have been previously discussed in this memorandum. The other design criteria appear to meet permit approvals and the residence times as stated on page 17 (Finding 45) of the Order.

3.18 Water Quality Management

3.18.1 Design Description

The following design criteria were used for water quality management:

- Provide sufficient hydraulic structure flow capacity to maximize flow through the managed cell to reduce residence time and maximize wind and flow-induced re-aeration.
- Design cells so that water levels can be raised or lowered for complete drainage.

The project elements have been designed to improve the existing water quality conditions within Ponds A16 and A17. Pond A16 would experience water quality improvements from the flushing of water twice a day by tide events above 3.2 feet NAVD. Pond A17 would experience water quality improvements from the breaching of the A17 intake WCS structure and levee lowering daily tidal prism exchange.

3.18.2 Permit Review

Water quality conditions for Pond A16 discharge have been established by the California Regional Water Quality Board – San Francisco Bay Region. It is uncertain after construction is complete whether the discharge would meet these requirements as stated on pages 37-39 (Effluent Limits 1-2 and Receiving Water Limitations 1-4) of the Order. However, the measures recommended in the McMillen design would provide increased mixing of water and decreased residence time in each pond unit. If water quality does not meet the standards upon construction completion, additional measures may also be required to bring water quality back within permit parameters and will be determined at that time. Potential measures to improve water quality are outlined in Provision 4 of the Order such as changing the surface area of the

pond or filling borrow ditches. Adaptive management actions will be analyzed in more detail during the monitoring phase of the project if decreased water quality conditions are encountered. Attachment B Table B-8 Project Objective 4 of the Order lists methods for monitoring parameters, comparing them to water quality objectives and recommends potential management actions. These methods will be used if adaptive management is required for the project.

Monitoring of Pond A16 discharge water quality will be performed on a yearly basis as stated on page 33 (Finding 98) and page 40 (Provision 7) of the Order and as outlined in the *South Bay Salt Pond Restoration Project Phase 1 Monitoring Plan* prepared in 2008. The monitoring will be compared against the Phase 1 adaptive management triggers and potential management actions to determine the success of the restoration. USFWS will also monitor and look for ways to improve water quality compliance with the Basin Plan as outlined in Provision 4 of the Order. A report will be submitted annually by March 1 of each year that has documented USFWS's efforts to improve water quality within Pond A16. As outlined in Provision 5 of the Order, these reports will be submitted for approval of the Executive Officer before any actions are taken to improve water quality.

3.19 Impact Volumes and Areas

The cut/fill volumes for the McMillen design described in this memorandum have been calculated for each of the design elements. The volumes for Pond A16 are presented in Table 2 and for Pond A17 are presented in Table 3. Volumes have been separated between cut/fill above and below the MHHW of the San Francisco Bay (7.49 NAVD88). The impact areas for the project are presented in Table 4.

Table 2. McMillen Design Pond A16 Fill/Removal Volumes

Design Element	Below MHHW		Above MHHW	
	Cut (cu yds)	Fill (cu yds)	Cut (cu yds)	Fill (cu yds)
Nesting Islands	40,000 ¹	57,000	--	--
A17 Intake WCS Removal	--	--	--	--
A17 Levee Lowering	--	--	--	--
A16 Intake WCS	--	--	--	--
A16 Intake Fish Screen ²	--	--	--	--
A16 Outlet WCS	1,000	1,600	1,000	1,200
A16 Outlet Pilot Channel	1,100	--	--	--
A16 Levee	100	300	--	200
A16 Intake WCS Levee	1,700	1,750	600	650
A17 Water Control Berm	--	--	--	--
A17 Fishing Platform	--	--	--	--
A16 Wildlife Viewing Platform	--	20	--	--
Crushed Rock Trail Surfacing	--	--	--	7,740
TOTAL VOLUME	43,900	60,670	1,600	9,790

¹ Cut calculated from the bay mud localized around each nesting island.

² Impacts associated with the fish screen are included in A16 intake wcs.

Table 3. McMillen Design Pond A17 Fill/Removal Volumes

Design Element	Below MHHW		Above MHHW	
	Cut (cu yds)	Fill (cu yds)	Cut (cu yds)	Fill (cu yds)
Nesting Islands	--	--	--	--
A17 Intake WCS Removal	1,500	--	1,000	--
A17 Levee Lowering	17,000 ¹	--	18,000 ¹	--
A16 Intake WCS	100	200	50	100
A16 Intake Fish Screen ²	--	--	--	--
A16 Outlet WCS	--	--	--	--
A16 Outlet Pilot Channel	--	--	--	--
A16 Levee	--	--	--	--
A16 Intake WCS Levee	1,700	1,750	600	650
A17 Water Control Berm	--	8,000	--	--
A17 Fishing Platform	--	20	--	--
A16 Wildlife Viewing Platform	--	--	--	--
Crushed Rock Trail Surfacing	--	10	--	1,260
TOTAL VOLUME	20,300	9,980	19,650	2,010

¹ Cut associated with levee lowering will be used for fill in the nesting islands, A16 levee, A16 intake wcs levee, A17 water control berm and/or filling borrow ditches.

² Impacts associated with the fish screen are included in A16 intake wcs.

Table 4. McMillen Design Pond A16-A17 Impact Areas

Design Element	Pond A16	Pond A17	Pond A16 Upland Levee	Pond A17 Upland Levee	Pond A16 Tidal Marsh	Pond A17 Tidal Marsh
New Tidal Wetland Restoration	-	130.14	-	-	-	-
New Managed Pond	236.43	-	-	-	-	-
Existing Upland Levee (No Impact)	-	-	15.89	1.41	-	-
Existing Tidal Marsh (No Impact) ¹	-	-	-	-	48.61	36.85
Design Element Impacts						
Nesting Islands	5.51	-	-	-	-	-
A17 Intake WCS Removal	-	0.03	-	0.04	-	0.05
A17 Levee Lowering	-	-	-	10.01	-	-
A16 Intake WCS	-	0.01	-	0.05	-	-
A16 Intake Fish Screen ²	-	-	-	-	-	-
A16 Outlet WCS	0.03	-	0.04	-	0.03	-
A16 Outlet Pilot Channel	-	-	-	-	0.12	-
A16 Levee	0.02	-	-	-	-	-
A16 Intake WCS Levee	-	-	-	-	0.16	0.16
A17 Water Control Berm	-	0.82	-	-	-	-
A17 Fishing Platform	-	-	-	-	-	0.02
A16 Wildlife Viewing Platform	0.01	-	-	-	-	-
Crushed Rock Trail Surfacing	-	-	4.74	0.88	-	0.01
TOTAL ACRES	242.00	131.00	20.67	12.39	48.92	37.09

¹ Cut Area below OHWM = 35.81 acres, Fill Area below OHWM = 6.78 acres, Temporary Disturbance below OHWM is approximated at 10.0 acres.

¹ The tidal marsh area was calculated from the outboard edge of the levee to the open water of Coyote Creek, Artesian Slough or other open water features.

² Impacts associated with the fish screen are included in A16 intake WCS..

The cut/fill volumes outlined in the California RWQB San Francisco Bay Region Waste Discharge Requirements and Water Quality Certification (Order No. R2-2008-0078) are presented in Table 5 and the impact areas are presented in Table 6.

Table 5. RWQB Order No. R2-2008-0078 Fill/Removal Volumes

Item	Cut (cu yds)	Fill (cu yds)
Table B-4. Pond A16 Phase I Action Cut and Fill Volumes (Attachment B Page 9)		
Cell Intake/Outlet Structures	703	844
Dredge Relic Channel and Place Sediment On-Site	1,320	1,320
Construct Earth Berms with Material On-Site	98,620	98,620
Islands – Excavate and Place Material	89,517	89,517
Pond Intake/Outlet Structures	5,322	6,441
<i>Backfill</i>	--	1,466
<i>Excavation – Control Structures</i>	3,644	--
<i>Excavation – Pilot Channel</i>	1,625	--
<i>Excavation – Structural</i>	22	--
<i>Fill – Excavation materials spread on-site</i>	--	4,975
<i>Trench Excavation</i>	31	--
Dredging for Water-Based Construction Access at Intake/Outlet Structures and Dredge Locks	70,000	70,000
Total	265,482	266,742

Table 6. RWQB Order No. R2-2008-0078 Impact Areas

Item	Impact Area (acres)
Table 3. Summary of Dredge and Fill Information for Phase I of the SBSRP (Page 7)	
Temporary Disturbance Area (Excluded from Total)	22.2
Dredge Area	110
Fill Area	35.2
Permanent Impacts (=Dredge+Fill Acres)	145.2
Pond Size	242
Acres Restored or Improved for Wildlife	97

The Order does not separate impact volumes or areas into specific design elements for the project; therefore, the cut/fill volumes and the impact areas were not compared directly based on the different methods for determining volumes and areas. However, a comparison of the project total volumes was calculated and the McMillen design consists of approximately one-quarter less cut/fill volumes than approved under the Order. This decrease in fill/removal reduces the impacts to the tidal habitat located in and surrounding Ponds A16 and A17.

3.20 Adaptive Management Plan

The Adaptive Management Plan that has been prepared for the South Bay Salt Pond Restoration Project (Attachment C of the Order) will be used for this Pond A16-A17 Restoration Project as described in Order Finding 90. Monitoring of the project will occur as outlined on pages 39-43 (Provisions 1-19) and Attachment C of the Order. This monitoring will identify problems (if any) associated with the restoration and allow USFWS to avoid impacts using the “staircase” approach. Through the implementation of the Adaptive Management Plan, USFWS will be able to determine the success of implementing tidal habitat restoration at the 50:50 ratio and potentially increase up to the 90:10 ratio for the entire South Bay Salt Pond Restoration Project.

Based on the proposed design of this project and the restoration of Pond A17 to tidal habitat, this project will increase the ratio of tidal habitat:managed pond as outlined in the Order in Table 2 Existing Habitats in the SBSRP Area and Proposed Habitat Changes from Phase I from 80:20 (2,840:709 acres) to 81:19 (2,971:709 acres). Table 1 in the Order specifically excluded Pond A17 size from the project total. This increase in tidal habitat does not increase the overall area of the Phase I Restoration Activities above the 90:10 ratio. The results of the South Bay Salt Pond Restoration Project Phase 1 activities will provide the necessary information required for the determination of what ratio is necessary to provide habitat for shorebirds and waterfowl. Future actions of the South Bay Salt Pond Restoration Project will be submitted to the RWQCB for approval so that the overall ratio of tidal marsh to managed pond stays within the endpoints approved in the Order.

4.0 CONSTRUCTION APPROACH

During development of the McMillen design and through further understanding of permit conditions, McMillen concluded that the project schedule can be accomplished in a timely manner while continuing to remain highly sensitive to habitat conditions and concerns.

4.1 Schedule

To expedite the permitting process and allow construction starting in the Fall of 2011, McMillen is proposing to break the project into two Stages. Stage 1 would consist of implementing the design elements that meet the existing permit approvals. Stage 2 would consist of design elements that are a variance from the existing permit approvals and may require re-initiation of the permitting process. Table 7 outlines the design elements that are proposed for each stage. Stage 1 construction activities may carry over into Stage 2.

Table 7. Construction Phasing

Item	Stage 1	Stage 2
Nesting Islands	X	X
A17 Levee Lowering along Coyote Creek and Artesian Slough		X
A17 Levee Lowering along southern levee		X
Existing A17 Intake Structure Removal		X
A16 Intake WCS		X
A16 Intake Fish Screen		X
A16 Outlet WCS	X	
A16 Outlet Pilot Channel	X	
A16 Levee		X
Intake WCS Levee		X
A17 Water Control Berm		X
A17 Fishing Platform		X
A16 Viewing Platform	X	
Interpretive Signage		X
Cable Fence		X
Crushed Rock Surfacing		X
Water Pollution Control Plant's Pipeline	X	

4.2 Biological Monitoring

Mobilization is expected to occur as early as August, 2011 to begin Stage 1 construction activities. Directly following mobilization, a pre-construction survey would be completed by a qualified biologist to determine the presence of any special-status species prior to dewatering. Monitoring for special-status species would be performed on an on-going basis during construction. Biological monitoring will be performed in accordance with the requirements outlined on pages 45-46 (Provisions 28-33) of the Order.

As required by existing permit approvals, the timing of construction would reduce the probability that impacts would occur to special-status fish and wildlife species. Table 5 presents a summary of the construction window conditions that have been applied to specific habitat windows based on the existing permits approvals. There are no construction window changes being requested for this project.

Table 5. Construction Window Restrictions

Species	Construction Restriction	Buffer (feet)
Western Snowy Plover	March 1 - September 15	600
Least Tern	April 15 - August 15	300
Nesting Water Birds	Year-round	200
California Clapper Rail	February 1 - August 31	700 ¹ 750 ²
Burrowing Owls	February 1 - August 31	250
Northern Harrier	late March - August	200
Common Yellowthroat and Song Sparrow	Year-round	50
Salt Marsh Harvest Mouse	Avoid construction in suitable habitat	--
Harbor Seals – Haul-out Site	March - May (pupping season) June - August (molting season)	200
Harbor Seals – Pupping Site	March - May (pupping season) June - August (molting season)	500
Steelhead – Levee Breaching	February 1 - May 31	--
Steelhead	December 1 - May 31	--

¹USFWS BO

²BCDC CN 10-03

McMillen plans to perform active hazing of suitable habitat to prevent birds from nesting as well as altering the substrate in certain locations that may attract birds to nest as approved under permit conditions. McMillen's schedule is currently planned to start after the majority of the construction restriction windows have ended. Once construction has started, active hazing would be employed so that portions of the site would not require seclusion during any portion of the project schedule. If special-status species are identified on the project site, McMillen will adhere to the conditions outlined in the environmental permits. McMillen will also adhere to the applicable conservation measures outlined in each of the South Bay Salt Pond Restoration Project permits as outlined in Section 2.0 during construction.

Construction activities will follow the provisions set forth on pages 46-51 (Provisions 34-60) so that adverse impacts do not occur to the surrounding environment. McMillen will use the appropriate BMP's for the project as stated on page 50 (Provision 48) of the Order

5.0 CONCLUSION

The purpose of this memorandum is to present the McMillen design (Attachment B) changes to the conceptual design (Attachment A) that was approved in each of the existing environmental permits. The McMillen design achieves the overall goals and objectives of the project as originally intended during the permitting process but has significantly reduced the cut and fill volumes associated with the project. McMillen has broken the project into two stages with the intent that Stage 1 construction activities will be covered under the existing permit approvals and can be constructed starting in the Fall of 2011. Stage 2 activities may require additional permit coordination and may take up to one year to complete this process.

5.1 Next Steps

This permitting memorandum is being submitted to the environmental regulatory agencies outlined in Section 2.1 to begin coordination of the permitting process for the McMillen design outlined in this memorandum. McMillen recommends that USFWS obtain a formal response from each of the regulatory agencies acknowledging the design changes and implications to the existing permit approvals (if any). After a formal response has been obtained, McMillen will begin coordinating with the regulatory agencies on any additional permitting requirements for Stage 2 construction activities (if necessary).

ATTACHMENT A

CONCEPTUAL DESIGN DRAWINGS

Pond A16

Introduction. The Alviso Pond A16 managed pond would be reconfigured to create islands for nesting birds and shallow water habitat for shorebird foraging (Figure 2-17). As specified in the Adaptive Management Plan (see Section 2.3 and Appendix D of this EIS/R) and described in the Pond A16

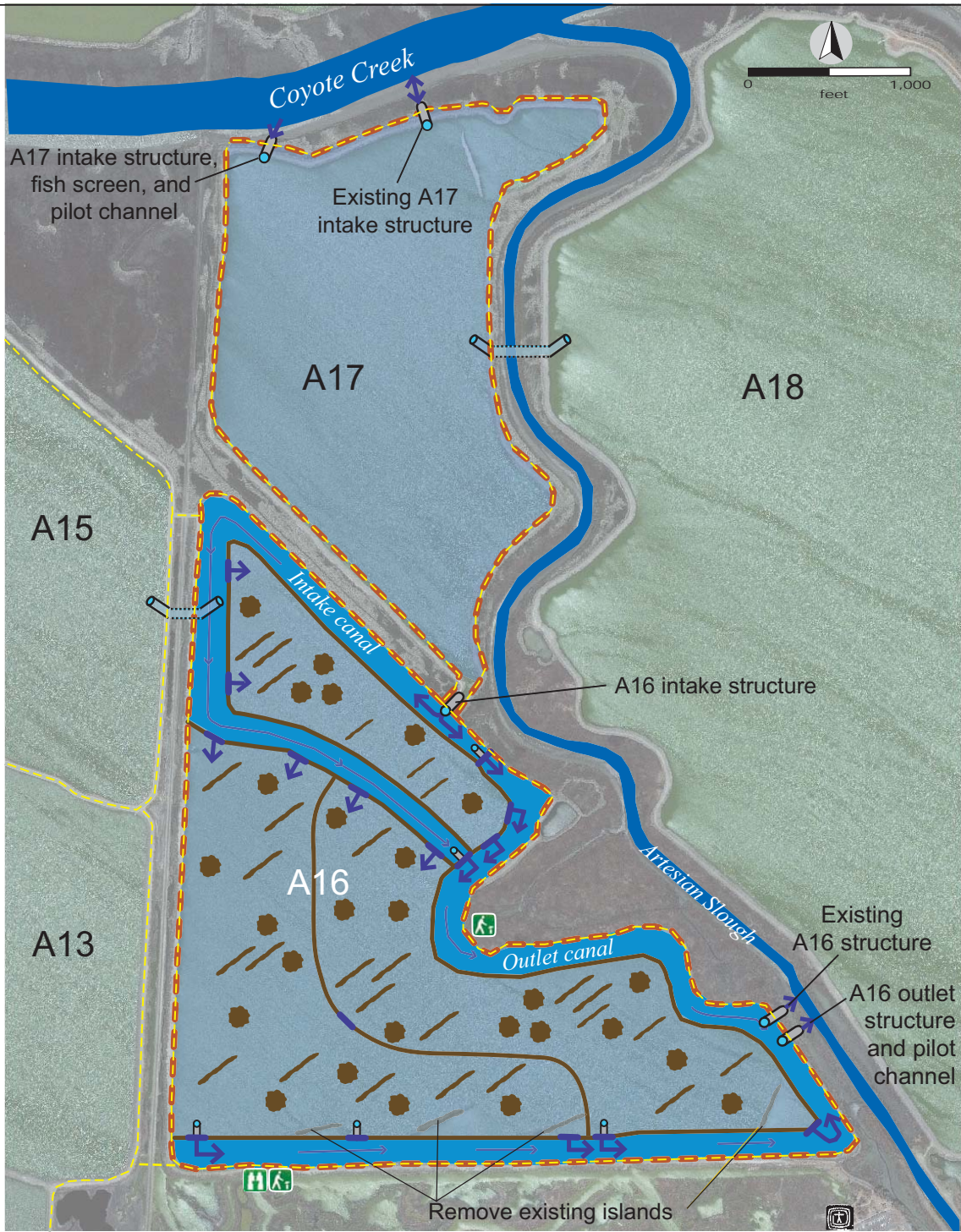

Cell intake/outlet water control structure:

- weir
- culvert with weir

Typical flow direction

Earth berm

Existing levee

Existing trail

Viewing platform

Interpretive station

Existing slough channel

Nesting island-linear

Nesting island-circular

Pond intake/outlet water control structure (culverts with gates)

Existing siphon

Viewing platform

Existing Environmental Education Center

South Bay Salt Pond
Restoration Project

figure 2-17

Alviso Pond A16
Phase 1 Action Restoration Plan

Figure by Philip Williams & Associates
Figure Date: 5-31-07

Adaptive Management section below, the Pond A16 restoration would test bird use for different island configurations as an applied study. The Pond A16 restoration would also test restoration techniques for vegetation management, predator management, and water quality management as part of the Adaptive Management Plan. Recreation and public access features for the Pond A16 restoration are described in the Alviso Recreation and Public Access Actions section below.

Restoration Plan. Pond A16 would be reconfigured to create islands for nesting birds and shallow water habitat for shorebird foraging (Figure 2-17). Three cells would be created within Pond A16. Nesting islands would be constructed in each cell. Water levels in each cell would be managed using water control structures to provide optimal depths for shorebird foraging. Water would flow into Pond A16 from Coyote Creek through Alviso Pond A17. Circulation through each cell in Pond A16 would be adaptively managed to meet water quality targets. Outflow from Pond A16 would discharge to Artesian Slough.

Nesting islands. Nesting islands would be constructed by grading the bottom of Pond A16. These islands are expected to be used for nesting by Forster's terns, American avocets, Caspian terns, black-necked stilts and snowy plovers. Different island shapes and densities would be created as an applied study (see the Pond A16 Adaptive Management section below). Each island would be approximately 3 ft (one m) high and have a surface area of approximately 15,000 square (sq) ft (1,400 sq m). The islands would be constructed using fill material excavated from the windward side of the islands. The islands would be located at least 300 ft (90 m) from the pond levees to provide a buffer between nesting birds and mammalian predators and to minimize disturbances by human activity on the levee (*e.g.*, passive recreation associated with the Refuge EEC). The islands would be located at least 600 ft (180 m) from any focal areas for human use, such as viewing platforms, benches, and the historic salt works. The existing islands along the southern edge of Pond A16 would be removed because these islands are close to the pond levee and proposed berm.

Berms. Cells would be created in Pond A16 by constructing low "check" berms around the cells, ranging in height from approximately 2 to 6 ft (0.6 to 2.0 m). The berms would be constructed by excavating fill material on-site. Pond bottom elevations vary from approximately 1 to 5 ft NAVD (0.3 to 1.5 m NAVD) and slope towards the southwest corner of the pond. Berms would be placed to: separate higher elevation areas from lower elevation areas, allow water levels to vary between different cells, and create cells with similar shallow water depths over the sloping pond bottom. Water depths in each cell would range from approximately 2 inches (five cm) to 1 ft (0.3 m) to provide foraging habitat for smaller and larger shorebirds.

Water management. The current water management plan for the Pond A16 restoration includes features to allow management flexibility and design redundancy. Using adaptive management, different water management approaches would be tested at Pond A16 to assess the effectiveness of providing optimal shallow water habitat and meeting water quality objectives (see the Pond A16 Adaptive Management section below).

Water would flow into Pond A16 through a new water control structure, such as one or more 48-inch culverts with adjustable tide gates. The new intake structure would be installed in the existing opening

(levee gap) between Pond A16 and Pond A17. The existing culvert with tide gates connecting Pond A17 to Coyote Creek (existing Pond A17 structure) would be opened to allow muted tidal action in Pond A17 and flow into Pond A16. In addition, a new intake water control structure, such as one or more 48-inch culverts with adjustable tide gates, would be installed between Pond A17 and Coyote Creek to increase the flow from Coyote Creek to Ponds A17 and A16. A pilot channel would be excavated through the existing vegetated fringe marsh between the new Pond A17 intake structure and Coyote Creek. If required by NOAA Fisheries, one or more fish screens would be installed on the new Pond A17 intake structure to prevent the entrapment of salmonid fish from Coyote Creek in Ponds A16 and A17 during the winter season (November through April). The existing Pond A17 structure could be closed during the winter season to prevent salmonid entrapment.

Intake and outlet canals would be created in Pond A16 to convey flow in and out of individual cells. The canals would be located around the perimeter of the cells in portions of the deep existing borrow ditch and remnant tidal channels in Pond A16. Water control structures, such as flashboard weirs, would be installed in the berms to regulate flow into and out of the cells. During low tides, water in the outlet canal would flow into Artesian Slough through the existing Pond A16 structure with tide gates between Pond A16 and Artesian Slough and a new outlet structure. The new Pond A16 outlet structure would consist of one or more 48-inch culverts with adjustable tide gates. A pilot channel would be excavated through the existing vegetated fringe marsh between the new Pond A16 outlet structure and Artesian Slough.

Water would be circulated through the cells in Pond A16 at rates sufficient to meet water quality objectives. The water quality objectives for Pond A16 would be to maintain adequate DO levels, salinity, and pH for habitat in the cells and to meet discharge requirements at the outlet structure. To test water management approaches within the Adaptive Management Plan, flows would be varied to assess the effects on DO levels and bird prey (see the Pond A16 Adaptive Management section below).

Flow through one of the cells could be modified without affecting the management of the other cells. Similarly, one cell could be completely drained of water for vegetation management (see the Pond A16 Adaptive Management section below) while other cells continue to provide shallow water habitat for shorebird foraging. Alternatively, water levels in Pond A16 could be periodically raised to inundate the nesting islands as a vegetation management technique. Raising water levels to inundate the island would also inundate the berms and water control structures and reduce the area of shallow water habitat.

Alviso Pond A15, which is part of the Alviso Pond A9 System (Ponds A9 through A15), is currently connected to Pond A16 by a siphon with a gate. High salinity water in Pond A15 can either flow into Pond A16 or back into the Pond A9 system through Pond A14. If Pond A16 is reconfigured, the existing siphon would be maintained, but high salinity water in Pond A15 would typically flow into Pond A14. The siphon could be opened to allow high salinity water to flow from Pond A15 into Pond A16 if water management or vegetation management call for higher salinity water.

Appendix G of this EIS/R (Alviso Pond A16 Hydraulic Modeling) documents hydraulic modeling performed to assess the feasibility of water management at Pond A16. The SBSP Nutrient and Contaminant Analysis Report (Appendix H) includes a water quality assessment for Pond A16.

Adaptive Management. Adaptive management for the Phase 1 action at Pond A16 would include both applied studies and restoration techniques, as specified in the Adaptive Management Plan (see Section 2.3 and Appendix D).

Applied Studies. Phase 1 experiments at Pond A16 would test:

1. The effects of island spacing and shape on nesting use and reproductive success.
2. The effects of vegetation type, density and distribution on island use by nesting birds.
3. The effects of nearby human activities on island use or nesting success.

Various nesting bird species may respond differently to contrasting island shapes. For example, terns may benefit more from circular islands while shorebirds such as black-necked stilts, American avocets, and snowy plovers may benefit from long, linear islands. In addition to contrasting shapes, it is important to understand the effect of island density on habitat value. For example, high-density islands may reduce foraging area between islands and increase aggressive interactions among family groups of American avocets and black-necked stilts. Vegetation also plays an important role in nesting success, as different birds species have varying vegetation tolerances or requirements. Snowy plovers typically avoid vegetated areas for nesting, and avocets usually nest in bare or sparsely vegetated areas. While some South Bay tern colonies are located in areas with little or no vegetation, other tern colonies, as well as many black-necked stilt nests, are located in areas having some vegetation, which may also provide shade and cover from predators for chicks. Nesting waterfowl are likely to nest almost exclusively in vegetated areas. Although human activity in the vicinity of Pond A16 would be expected to be limited to non-motorized recreation (*i.e.*, walking or biking around the outer levee of the pond) and O&M (see Section 2.5.6), it is unknown whether this level of activity would affect island use or nesting success by birds.

The experimental studies designed for Pond A16 would provide an important model for island design, provide an understanding of the vegetation requirements, and determine an acceptable level of human activity for reproductive success of bird species using this pond. This understanding would help inform and guide the design of optimal pond configurations that would be used at other locations in the South Bay.

- *Island spacing and shape.* Varying densities of islands would be created within Pond A16 to study the effects on bird nesting. There would be two island shapes: circular and linear (much longer than wide) to determine whether various nesting bird species respond differently to contrasting island shapes.
- *Vegetation type, density, and distribution.* Vegetation is expected to establish on some of the islands after one or more years. At that point, the vegetation can either be controlled or vegetation can be manipulated by planting or selective removal, to determine the effects of vegetation type, density, and spatial distribution on nesting use and reproductive success of bird populations. The species composition, type of vegetation, and vegetation distribution would be manipulated by planting or selective control/removal to conduct studies to determine the effects and distribution of vegetation on nesting success. The decision regarding which plant species

would be used in actual experiments would be determined by monitoring which vegetation types colonize (and thus can be expected to survive on the islands) during the first few years following island construction.

- Human activity. To determine whether human activities affect nesting birds at Pond A16, a portion of the trail (*e.g.*, along the entire northeastern side of the pond) could be closed during the breeding season every other year. The number of nests, nest success and fledging success would be determined for each island to determine whether the number and breeding success of birds on islands near the closed levee differs with full human access versus limited human access, and whether in years of limited human access the nesting bird populations vary substantially.

Restoration Techniques. Three restoration techniques would be tested in the Phase 1 actions at Pond A16:

1. Management of water to meet regulatory standards and creation of high quality bird habitat;
 2. Management of vegetation growth in the pond and on islands;
 3. Management of predators;
- Water management. Water in Pond A16 would be managed to maintain water quality to meet regulatory standards. Dissolved oxygen (DO) is an important water quality parameter in managed pond environments. DO concentrations are influenced by factors such as water temperature, phytoplankton abundance, mixing, and hydraulic residence time. Maintaining adequate DO concentrations in other managed ponds has been problematic during certain periods, such as warm summer months. At Pond A16, it may be necessary to increase flows and decrease residence times in the pond during warmer months to maintain adequate DO concentrations. Residence time may affect the abundance and productivity of invertebrates or fish, due to predation by birds nesting within the pond. The water control structures at Pond A16 would be adjusted to vary flow rates and study relationships between residence time, DO, phytoplankton abundance, and invertebrate productivity. In addition, other techniques to maintain DO concentrations may be tested, such as mechanically mixing pond water to induce re-aeration, re-aerating the discharge, or importing material to fill portions of the deep borrow ditches that have shown to be problematic for DO during ISP operations (May and Abusaba 2007).
 - Vegetation management. While vegetation on nesting islands may benefit some bird species, vegetation management is expected to be necessary to maintain habitat for species averse to nesting in vegetation (*e.g.*, snowy plovers and American avocets) and to prevent dense, tall vegetation from encroaching on islands, and in shallow water foraging areas. Experimentation with various methods of vegetation management would be conducted to determine the methods that are most effective, and most cost-effective, in controlling vegetation. These methods would be implemented primarily during the non-breeding season. Methods that may be implemented to control vegetation on islands include maintaining substrate types for long-term effectiveness, mechanical control of vegetation by cutting, disking or raking, herbicide use, burning, spraying with highly saline water, or periodically raising water levels in Pond A16 to inundate the islands. Salvaged and recycled gypsum may be experimentally used as a vegetation-restricting measure

on roosting or nesting islands. Access and equipment for vegetation management may include trucks, boats, low-pressure construction equipment, and/or other equipment.

- Predator management. Predation would likely be an important factor limiting the number and success of nesting birds using the islands in Pond A16. Mammalian predation is not expected to be a problem, given the distance of the nesting islands from the pond edge and the ongoing predator control being employed by the Refuge. Avian predation is expected to be a concern. Predator management approaches would vary depending on the type of predator involved, and may vary depending on whether or not predators are nesting within the pond (e.g., gulls on islands). As a result, specific experiments to control predators would be designed once the nature and magnitude of predation is observed. Methods of reducing the effects of avian predation on nesting islands could include: hazing and removal of nest starts; provisions for vegetative or artificial cover (e.g., chick shelters); trapping and relocation of predators within or near Pond A16; or lethal removal of individual problem avian predators if live capture is not successful.

Restoration Monitoring. Restoration monitoring would be performed to evaluate restoration performance and inform adaptive management, including the applied studies and restoration techniques. O&M inspections are discussed in the Operations and Maintenance section in Section 2.5.6.

- Island spacing and shape. Weekly surveys would be conducted throughout the breeding season to determine the number of nesting bird pairs/species on each island, and surveys at least once per week on a sample of islands would determine nesting success (proportion of nests that hatch at least one young) and fledging success. Surveys would be conducted from the levee around Pond A16, and from the interior of the pond as needed, by an observer using a spotting scope.
- Vegetation. Data on the percent cover, height, and density of vegetation (overall and by species) in random cells of a grid on each island would be collected.
- Predator management. Data would be collected on nest and fledging success of nesting terns and shorebirds on nesting islands, predation attempts and predation success on selected islands or in cells with different predator management treatments.
- Water management. During the late summer (after nesting has been completed), the flow rate would be varied to adjust the residence time of water within the pond. DO, water temperature, water depth, and salinity would be measured, and invertebrates would be sampled at 10 locations within each of the four cells on a weekly basis. Water levels would be managed to reduce the risk of low DO levels, so as to avoid fish kills, but evidence of any fish kills would be noted. The relationships between flow rate, air temperature, water temperature, and water depth on DO would be determined, and the relationships between these variables, DO, and salinity on invertebrate abundance would be determined.

Phase 1 Recreation and Public Access Actions

The recreational features within the Alviso pond complex would be managed by USFWS as part of the current public access program at the Refuge. The public access and recreation plan for the Phase 1 actions at the Alviso pond complex would occur in three principal locations near Ponds A16 and near Ponds A2E and A3W. See Figures 2-18 through 2-20 for plans that highlight recreation and public access in these locations.

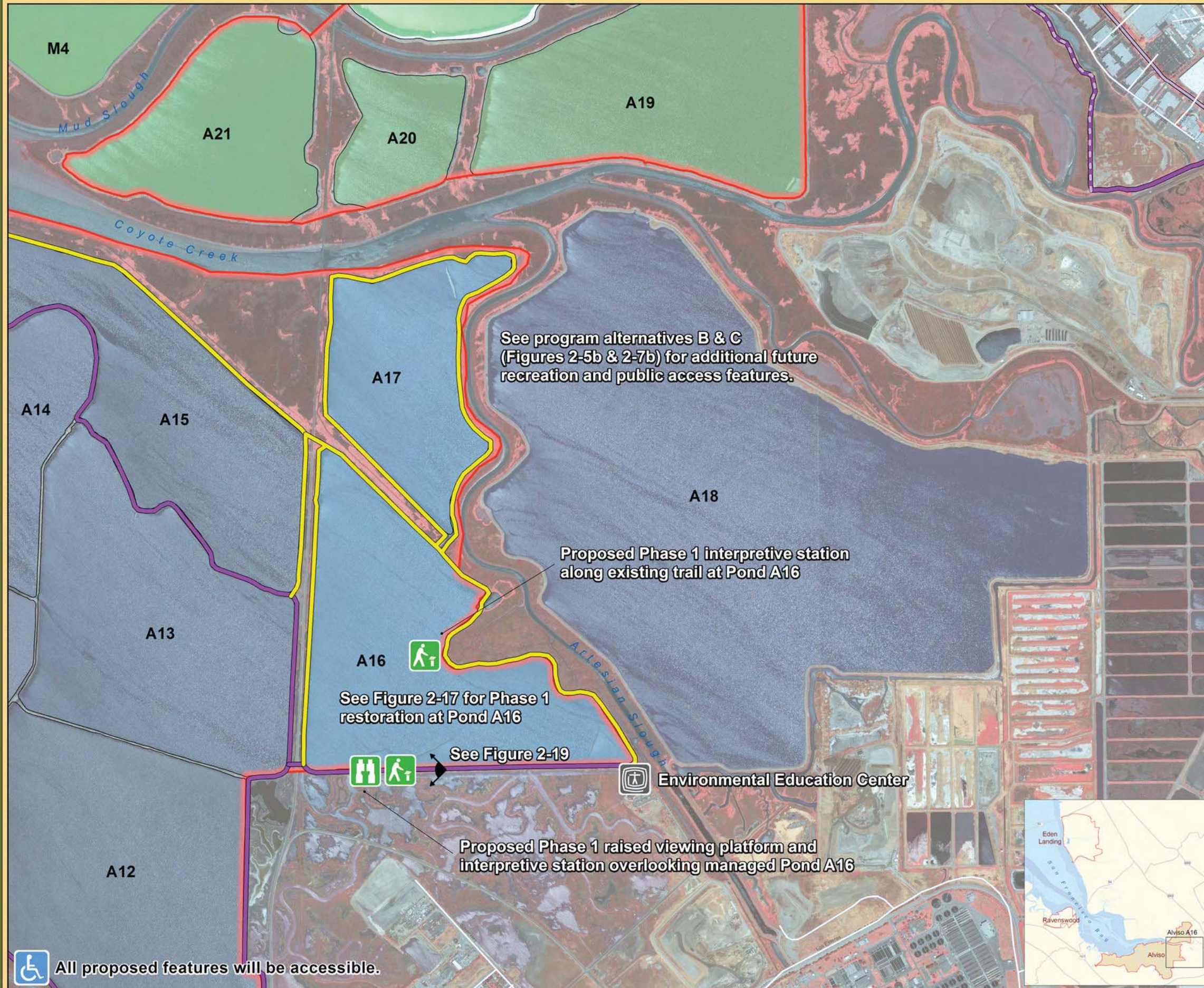

South Bay Salt Pond Restoration Project

Figure 2-18. Alviso Pond A16 Phase 1 Recreation Actions



-  Project Area

- Habitat Features**

 -  Managed Pond
 -  Tidal Habitat



- Trail Features**

 -  Existing Trail

- Existing Bay Trail**
(Association of Bay Area Governments)

 -  Spine Trail



- Bike Trails**

 -  Cyclists and Pedestrians
 -  Cyclist Lane or Signed Roads

- Existing Recreation Facilities**

 -  Environmental Education Center

- Proposed Recreation Facilities**

 -  Interpretive Station
 -  Viewing Platform

-  Viewpoint

-  N
- 0 1,000 2,000 3,000 Feet
- 0 300 600 900 Meters

Map datum and projection: NAD83, UTM Zone 10N
 Map data: San Francisco Estuary Institute (habitats, bay shoreline, aqueduct); EDAW (project boundary); Cargill (ponds, buildings); Bay Area Open Space Council (highways).
 Map by: EDAW
 Map date: March, 2007

ATTACHMENT B
MCMILLEN DESIGN DRAWINGS



DON EDWARDS SAN FRANCISCO BAY NWR

POND A16 - A17 RESTORATION

Santa Clara County, California

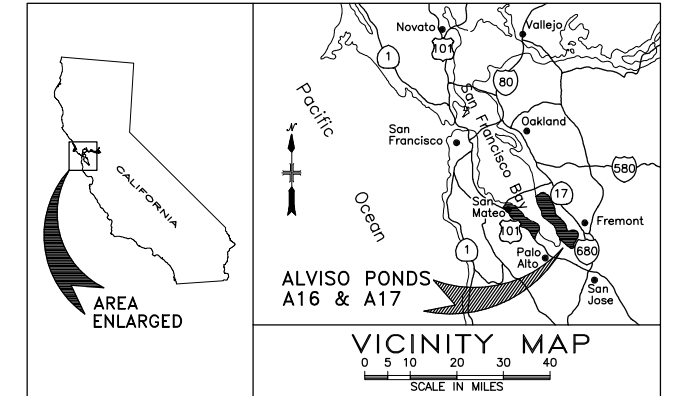

LOCATION MAP
NOT TO SCALE

PROJECT DIRECTORY

TECHNICAL
U.S. FISH AND WILDLIFE SERVICE
R-1 / R-8 ENGINEERING
911 NE 11th AVENUE
PORTLAND, OR 97232-4181
503-231-6145 FAX 503-231-6847

FIELD STATION
U.S. FISH AND WILDLIFE SERVICE
DON EDWARDS SAN FRANCISCO BAY
NATIONAL WILDLIFE REFUGE
9500 THORNTON AVENUE
NEWARK, CA 94560
510-792-0222

PHYSICAL PROJECT LOCATION
FROM HIGHWAY 237, EXIT ON ZANKER RD. TRAVEL NORTH FOR 2.1 MILES, TURN RIGHT ONTO GRAND BLVD. THE PROJECT IS LOCATED 0.85 MILES NORTH ON GRAND BLVD. SANTA CLARA COUNTY, CALIFORNIA

PROJECT DESCRIPTION
RESTORE AND ENHANCE WETLANDS IN THE SAN FRANCISCO BAY AREA, WHILE PROVIDING FOR FLOOD MANAGEMENT AND WILDLIFE ORIENTED PUBLIC ACCESS AND RECREATION, SPECIFICALLY RELATED TO PONDS A16 AND A17 OF THE ALVISO PORTION OF THE DON EDWARDS NATIONAL WILDLIFE REFUGE.

U.S. FISH & WILDLIFE SERVICE
WORKING WITH OTHERS TO
CONSERVE, PROTECT AND ENHANCE
FISH, WILDLIFE, PLANTS, AND THEIR
HABITATS FOR THE CONTINUING
BENEFIT OF THE AMERICAN PEOPLE.

REV.	DATE	DESCRIPTION	BY
UNITED STATES DEPARTMENT OF THE INTERIOR FISH AND WILDLIFE SERVICE REGION 1, OFFICE OF ENGINEERING PORTLAND, OREGON			
SUBMITTED BY PROJECT MANAGER		DON EDWARDS SAN FRANCISCO BAY NATIONAL WILDLIFE REFUGE POND A16-A17 RESTORATION VICINITY MAP AND LOCATION MAP	
REVIEWED FOR SAFETY COMPLIANCE			
REVIEWED FOR ENVIRONMENTAL COMPLIANCE			
REVIEWED FOR ADA COMPLIANCE			
CERTIFIED TO CFR 435 COMPLIANCE (ENERGY)		SANTA CLARA COUNTY CALIFORNIA	
SUBMITTED BY REGIONAL ENGINEER		SURVEYED	DESIGNED DA
PROGRAMMATIC REVIEW		DATE	DRAWN RW
		9/9/11	CHECKED CB
		DRAWING NO. 8R-CA-898-182-1.0	

DESIGN PERMIT DRAWINGS

McMILLEN, LLC

1401 SHORELINE DR. OFFICE: 208.342.4214
STE 100 BOISE, ID 83702 FAX: 208.342.4216

VERIFY SCALE

THIS BAR IS ONE INCH ON ORIGINAL DRAWING
0" — 1"
ADJUST SCALES ACCORDINGLY, IF NOT ONE INCH ON THIS SHEET

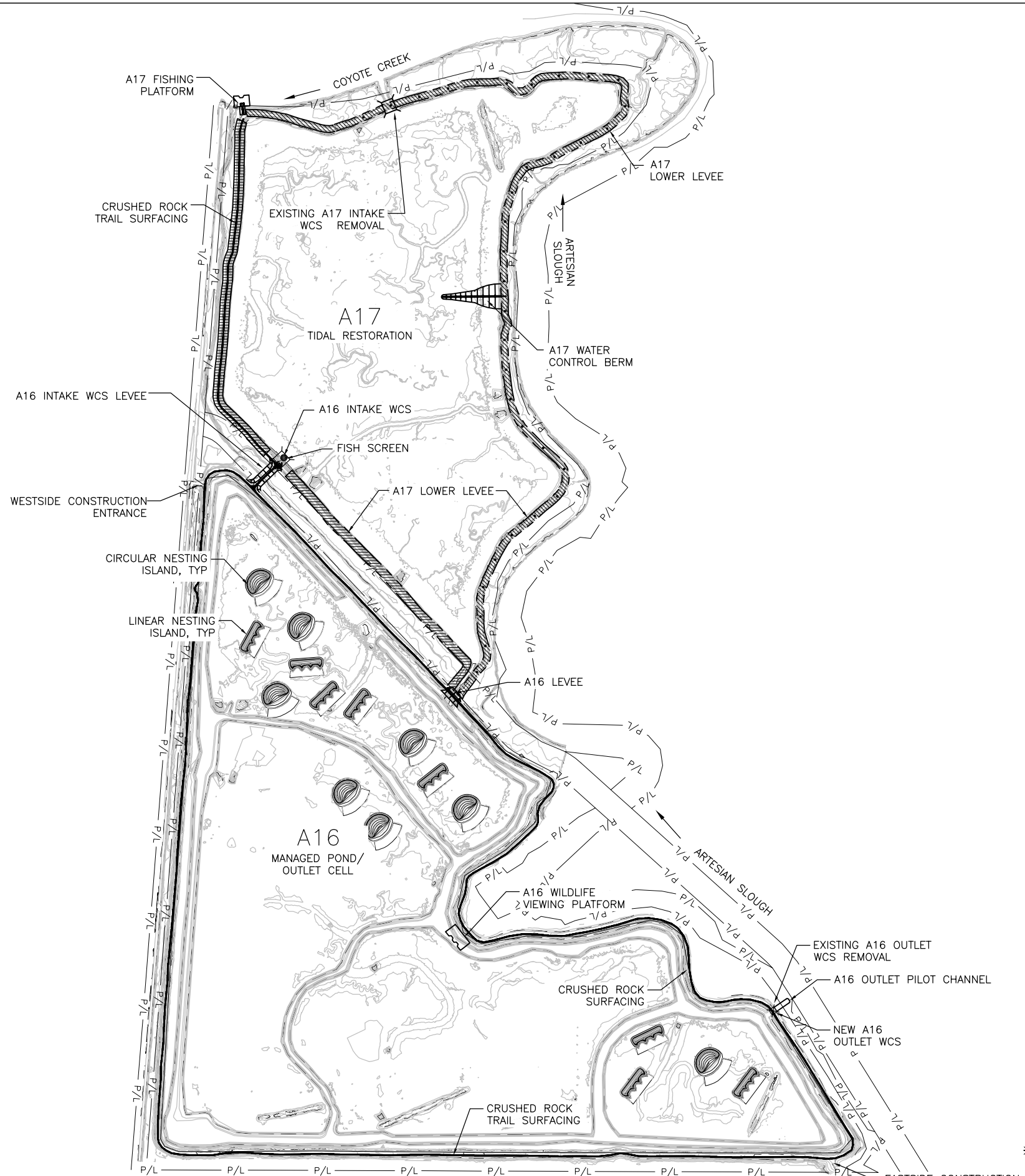

OVERALL SITE PLAN
NTS

LEGEND			
DESCRIPTION	QUANTITY	STAGE	SYMBOL
CIRCULAR NESTING ISLAND	8 SITES	STAGE I & II	
LINEAR NESTING ISLAND	8 SITES	STAGE I & II	
A17 LOWER LEVEE	9,310 LINEAR FEET	STAGE II	
BERM OR LEVEE	780 LINEAR FEET	STAGE II	
A16 INTAKE WCS	1 EACH	STAGE II	
A16 OUTLET WCS	1 EACH	STAGE I	
CABLE FENCE	500 LINEAR FEET	STAGE II	
A16 OUTLET PILOT CHANNEL	200 LINEAR FEET	STAGE I	
FISH SCREEN	1 EACH	STAGE II	
PLATFORMS	2 EACH	STAGE I & II	
CRUSHED ROCK TRAIL SURFACING	20,000 LINEAR FEET	STAGE II	



DESIGN PERMIT DRAWINGS

McMILLEN, LLC

1401 SHORELINE DR.
STE 100
BOISE, ID 83702

OFFICE: 208.342.4214
FAX: 208.342.4216

VERIFY SCALE

THIS BAR IS ONE INCH ON ORIGINAL DRAWING

0" ————— 1"

ADJUST SCALES ACCORDINGLY, IF NOT ONE INCH ON THIS SHEET

REV.	DATE	DESCRIPTION	BY

DON EDWARDS SAN FRANCISCO BAY NWR

POND A16-A17 RESTORATION

OVERALL SITE PLAN

SHEET
2

DESIGNED	DA	DRAWN	RW	CHECKED	CB	DATE	9/9/11	DRAWING NO.	8R-CA-898-182-2.0
----------	----	-------	----	---------	----	------	--------	-------------	-------------------

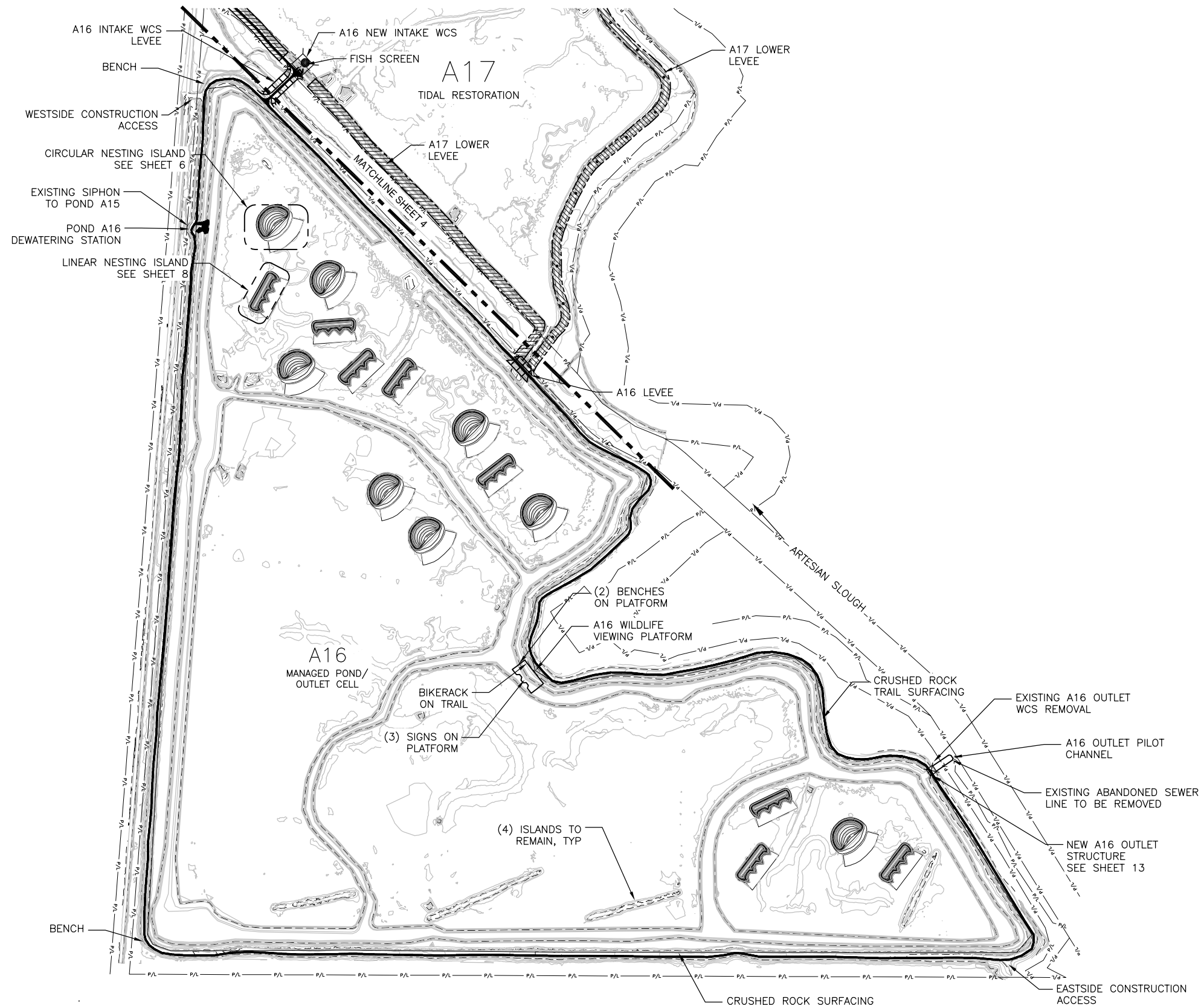

LEGEND			
DESCRIPTION	QUANTITY	STAGE	SYMBOL
CIRCULAR NESTING ISLAND	8 SITES	STAGE I & II	
LINEAR NESTING ISLAND	8 SITES	STAGE I & II	
A17 LOWER LEVEE	9,310 LINEAR FEET	STAGE II	
NEW BERM OR LEVEE	780 LINEAR FEET	STAGE II	
A16 INTAKE WCS	1 EACH	STAGE II	
A16 OUTLET WCS	1 EACH	STAGE I	
CABLE FENCE	500 LINEAR FEET	STAGE II	
A16 OUTLET PILOT CHANNEL	200 LINEAR FEET	STAGE I	
FISH SCREEN	1 EACH	STAGE II	
PLATFORMS	2 EACH	STAGE I & II	
CRUSHED ROCK TRAIL SURFACING	20,000 LINEAR FEET	STAGE II	

POND A16 PLAN

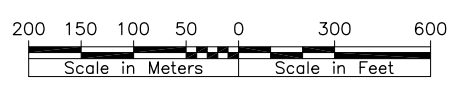

DESIGN PERMIT DRAWINGS

McMILLEN, LLC
 1401 SHORELINE DR.
 STE 100
 BOISE, ID 83702
 OFFICE: 208.342.4214
 FAX: 208.342.4216

VERIFY SCALE
 THIS BAR IS ONE INCH ON ORIGINAL DRAWING
 0" = 1"
 ADJUST SCALES ACCORDINGLY, IF NOT ONE INCH ON THIS SHEET

REV.	DATE	DESCRIPTION	BY

DON EDWARDS SAN FRANCISCO BAY NWR
POND A16-A17 RESTORATION
POND A16 PLAN SHEET 3

DESIGNED DA	DRAWN RW	CHECKED CB	DATE 9/9/11	DRAWING NO. 8R-CA-898-182-3.0
-------------	----------	------------	-------------	-------------------------------

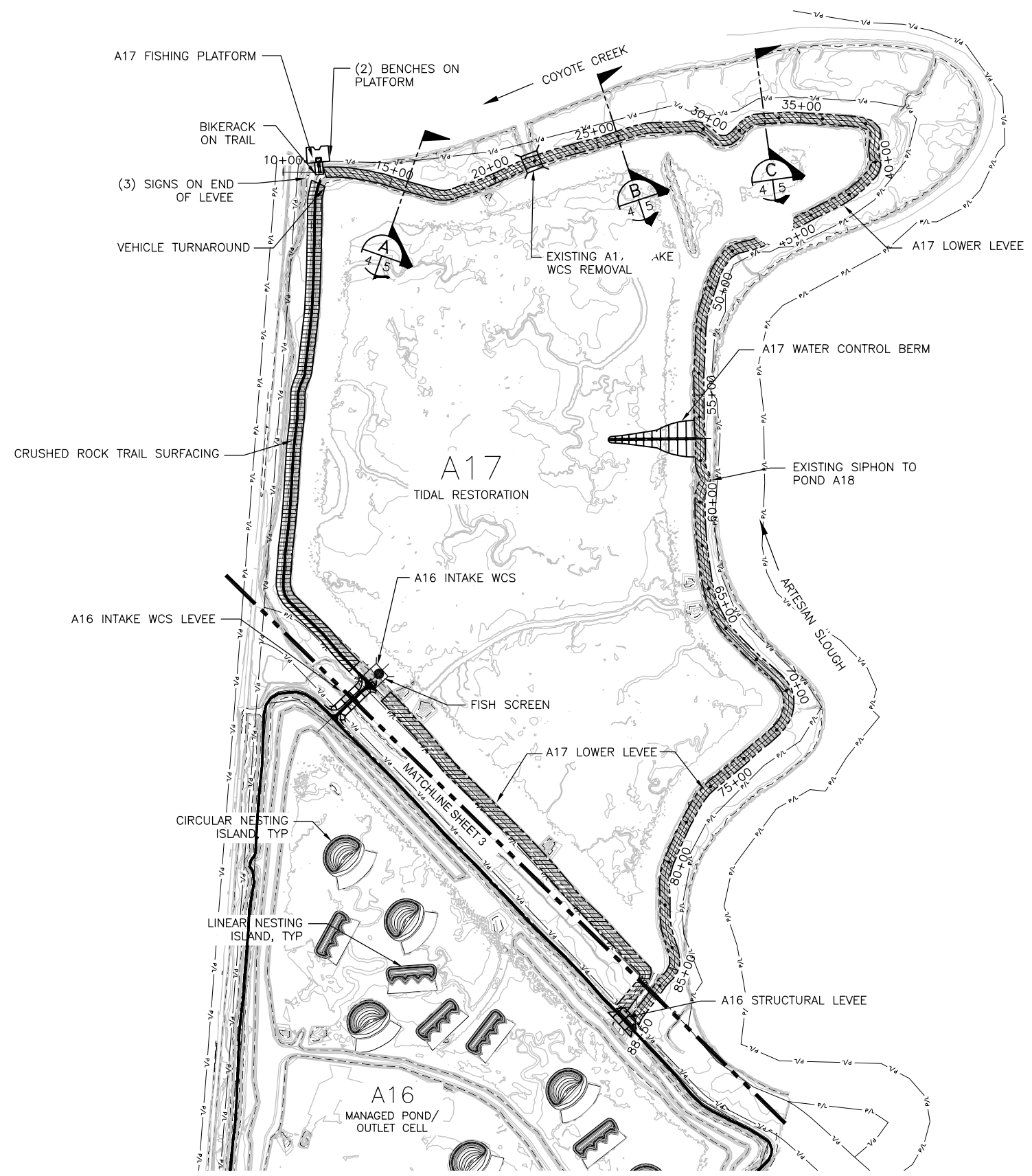

NOTES:

1. SMALL UPLAND HUMMOCKS WILL BE LEFT IN THE A17 TIDAL LEVEE EVERY 200 FEET AFTER LOWERING TO PROVIDE ESCAPE COVER DURING HIGH TIDE EVENTS FOR SALT MARSH HARVEST MICE.

LEGEND

DESCRIPTION	QUANTITY	STAGE	SYMBOL
CIRCULAR NESTING ISLAND	8 SITES	STAGE I & II	
LINEAR NESTING ISLAND	8 SITES	STAGE I & II	
A17 LOWER LEVEE	9,310 LINEAR FEET	STAGE II	
NEW BERM OR LEVEE	780 LINEAR FEET	STAGE II	
A16 INTAKE WCS	1 EACH	STAGE II	
A16 OUTLET WCS	1 EACH	STAGE I	
CABLE FENCE	500 LINEAR FEET	STAGE II	
A16 OUTLET PILOT CHANNEL	200 LINEAR FEET	STAGE I	
FISH SCREEN	1 EACH	STAGE II	
PLATFORMS	2 EACH	STAGE I & II	
CRUSHED ROCK TRAIL SURFACING	20,000 LINEAR FEET	STAGE II	

POND A17 PLAN

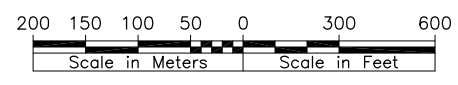

DESIGN PERMIT DRAWINGS

McMILLEN, LLC
 1401 SHORELINE DR.
 STE 100 BOISE, ID 83702
 OFFICE: 208.342.4214
 FAX: 208.342.4216

VERIFY SCALE
 THIS BAR IS ONE INCH ON ORIGINAL DRAWING
 0" = 1"
 ADJUST SCALES ACCORDINGLY, IF NOT ONE INCH ON THIS SHEET

REV.	DATE	DESCRIPTION	BY

DON EDWARDS SAN FRANCISCO BAY NWR
POND A16-A17 RESTORATION
POND A17 PLAN

DESIGNED DA DRAWN CS CHECKED CB DATE 9/9/11 DRAWING NO. 8R-CA-898-182-4.0

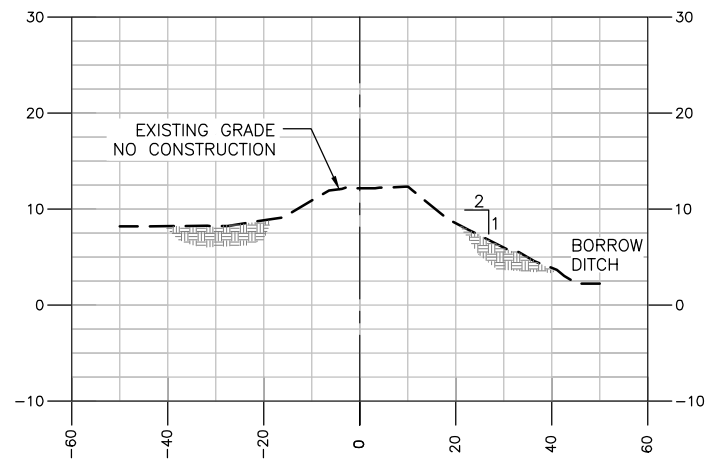

A TYPICAL LEVEE SECTION
4 | 5

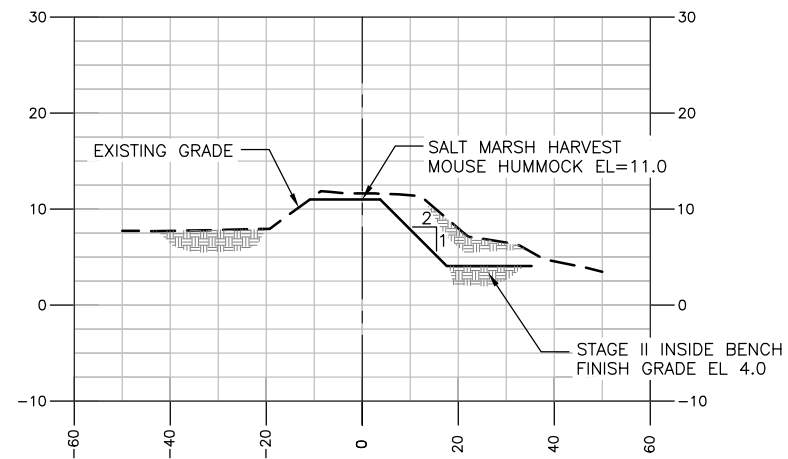

B TYPICAL SALT MARSH HARVEST
MOUSE HUMMOCK SECTION
4 | 5

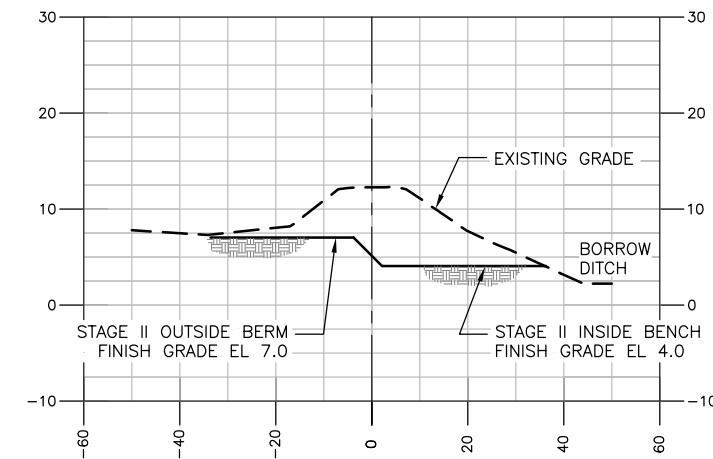

C TYPICAL LOWERED LEVEE SECTION
4 | 5

LEGEND:
--- EXISTING GRADE

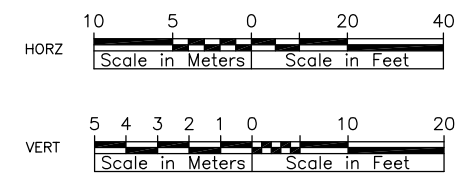

DESIGN PERMIT DRAWINGS

McMILLEN, LLC

1401 SHORELINE DR.
STE 100
BOISE, ID 83702
OFFICE: 208.342.4214
FAX: 208.342.4216

VERIFY SCALE
THIS BAR IS
ONE INCH ON
ORIGINAL DRAWING
0" ————— 1"
ADJUST SCALES
ACCORDINGLY, IF
NOT ONE INCH
ON THIS SHEET

REV.	DATE	DESCRIPTION	BY

DON EDWARDS SAN FRANCISCO BAY NWR
POND A16-A17 RESTORATION
A17 LOWER LEVEE SECTIONS

DESIGNED GA DRAWN RW CHECKED MM DATE 9/9/11 DRAWING NO. 8R-CA-898-182-5.0

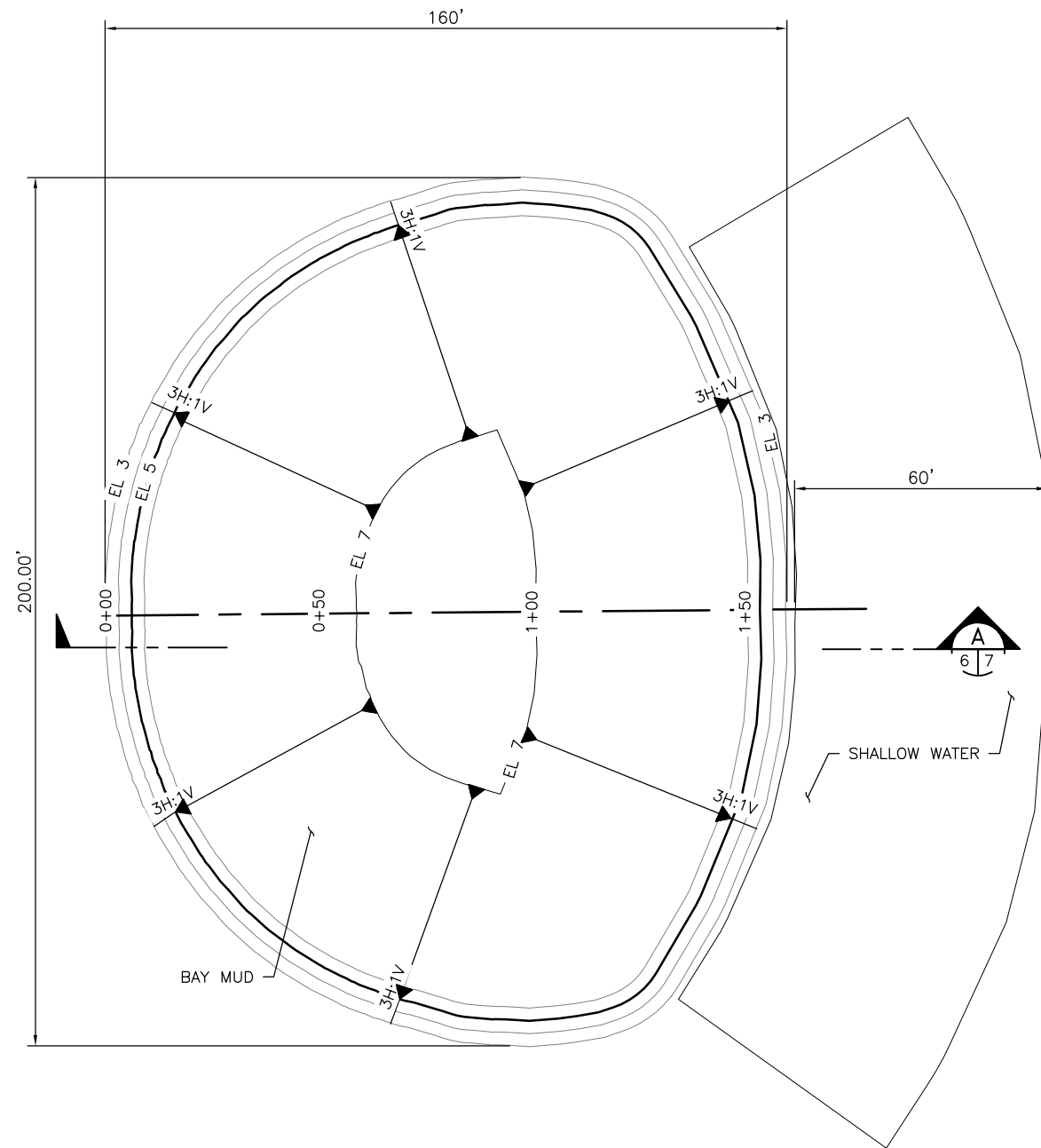

TYPICAL CIRCULAR NESTING ISLAND PLAN
STAGE I

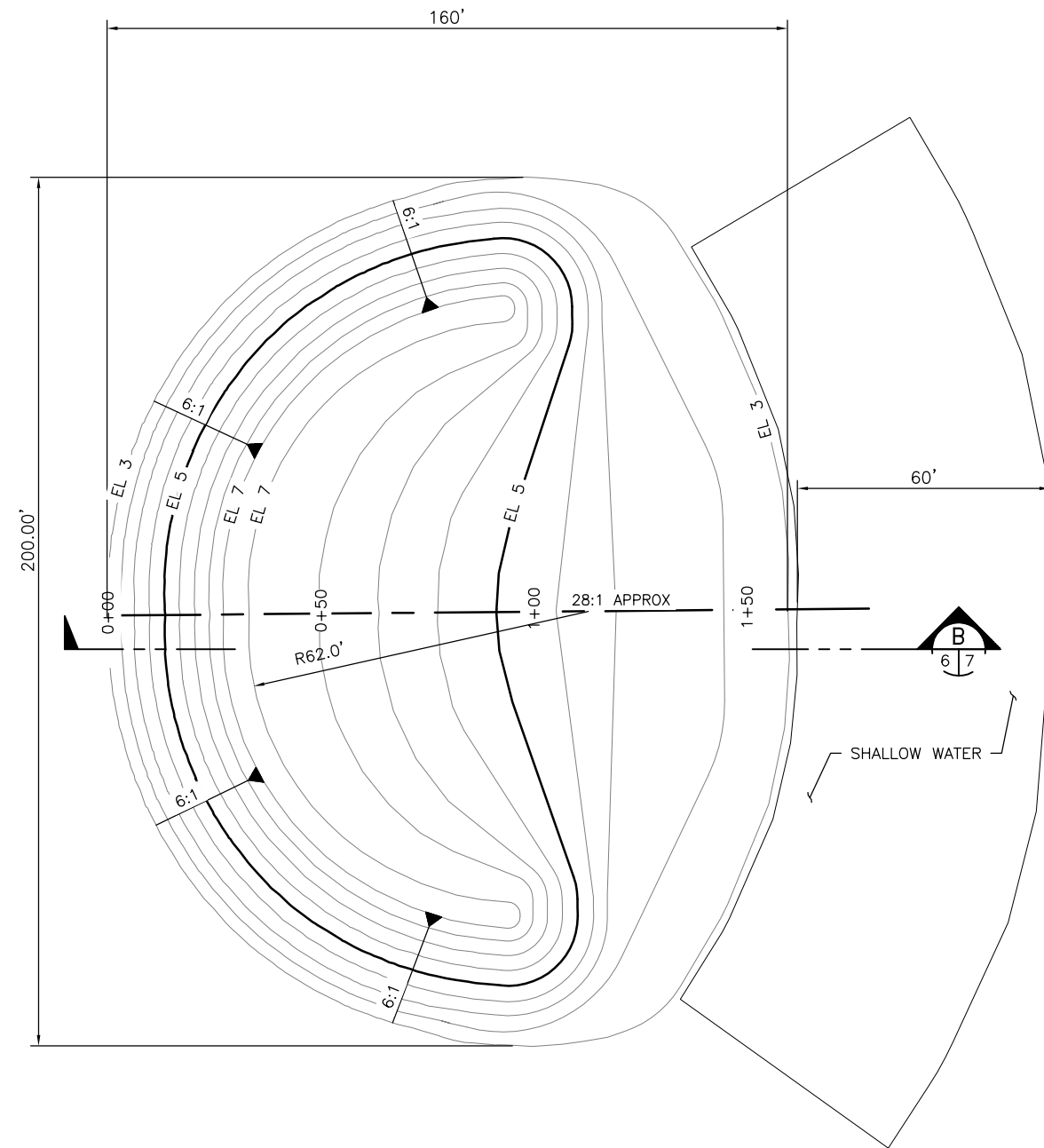
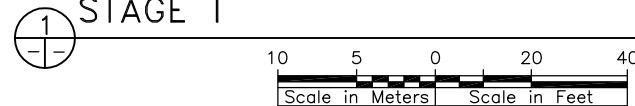

TYPICAL CIRCULAR NESTING ISLAND PLAN
STAGE II

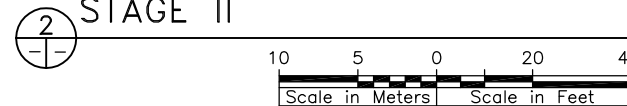

DESIGN PERMIT DRAWINGS

McMILLEN, LLC

1401 SHORELINE DR.
STE. 100
BOISE, ID 83702
OFFICE: 208.342.4214
FAX: 208.342.4216

VERIFY SCALE
THIS BAR IS
ONE INCH ON
ORIGINAL DRAWING
0" — 1"
ADJUST SCALES
ACCORDINGLY, IF
NOT ONE INCH
ON THIS SHEET

REV.	DATE	DESCRIPTION	BY

DON EDWARDS SAN FRANCISCO BAY NWR
POND A16-A17 RESTORATION
CIRCULAR NESTING ISLANDS PLAN

DESIGNED DA DRAWN RW CHECKED CB DATE 9/9/11 DRAWING NO. 8R-CA-898-182-6.0

SHEET
6

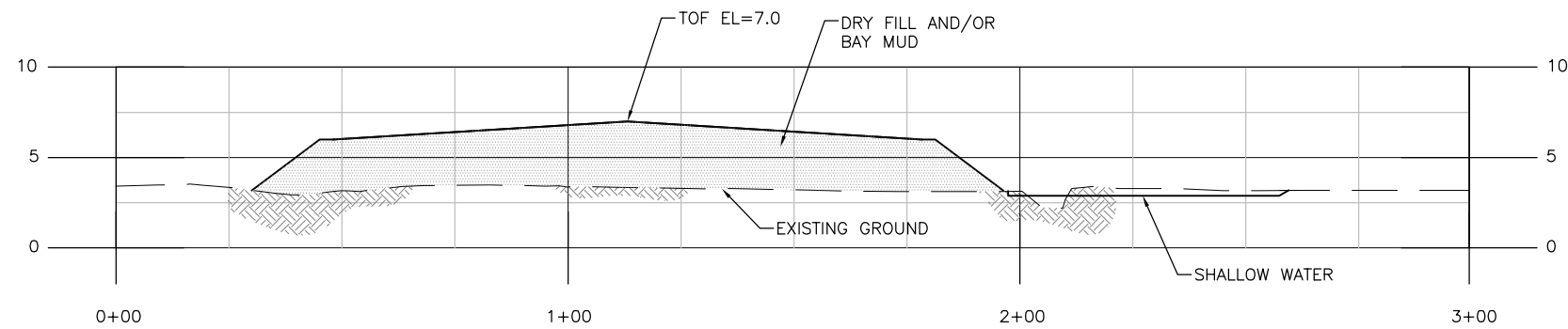

A
6 | 7
TYPICAL CIRCULAR NESTING ISLAND SECTION STAGE I

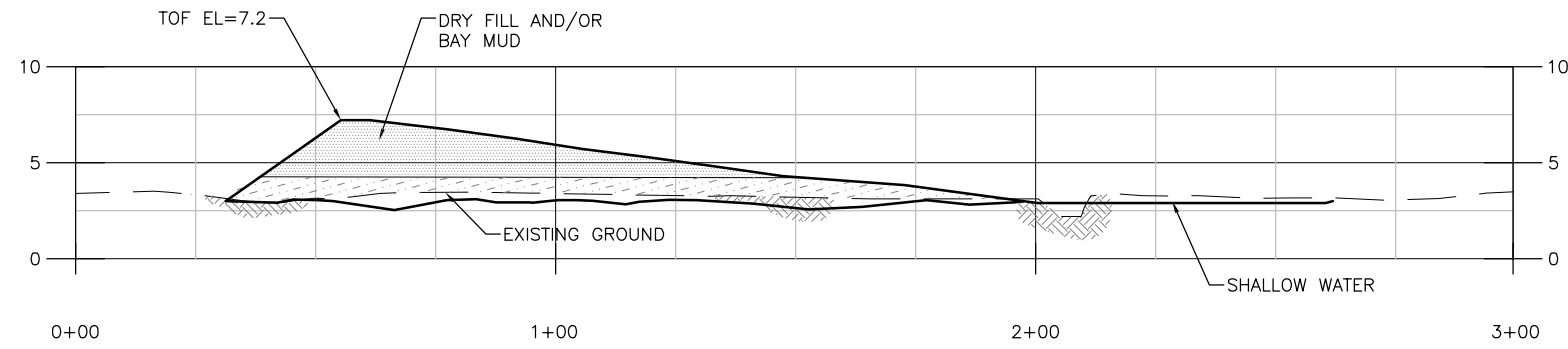

B
6 | 7
TYPICAL CIRCULAR NESTING ISLAND SECTION STAGE II

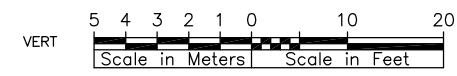
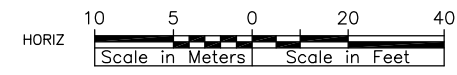

DESIGN PERMIT DRAWINGS

McMILLEN, LLC
1401 SHORELINE DR.
STE. 100
BOISE, ID 83702
OFFICE: 208.342.4214
FAX: 208.342.4216

VERIFY SCALE
THIS BAR IS ONE INCH ON ORIGINAL DRAWING
0" = 1"
ADJUST SCALES ACCORDINGLY, IF NOT ONE INCH ON THIS SHEET

REV.	DATE	DESCRIPTION	BY

DON EDWARDS SAN FRANCISCO BAY NWR
POND A16-A17 RESTORATION
CIRCULAR NESTING ISLANDS SECTION

DESIGNED DA DRAWN RW CHECKED MM DATE 9/9/11 DRAWING NO. 8R-CA-898-182-7.0

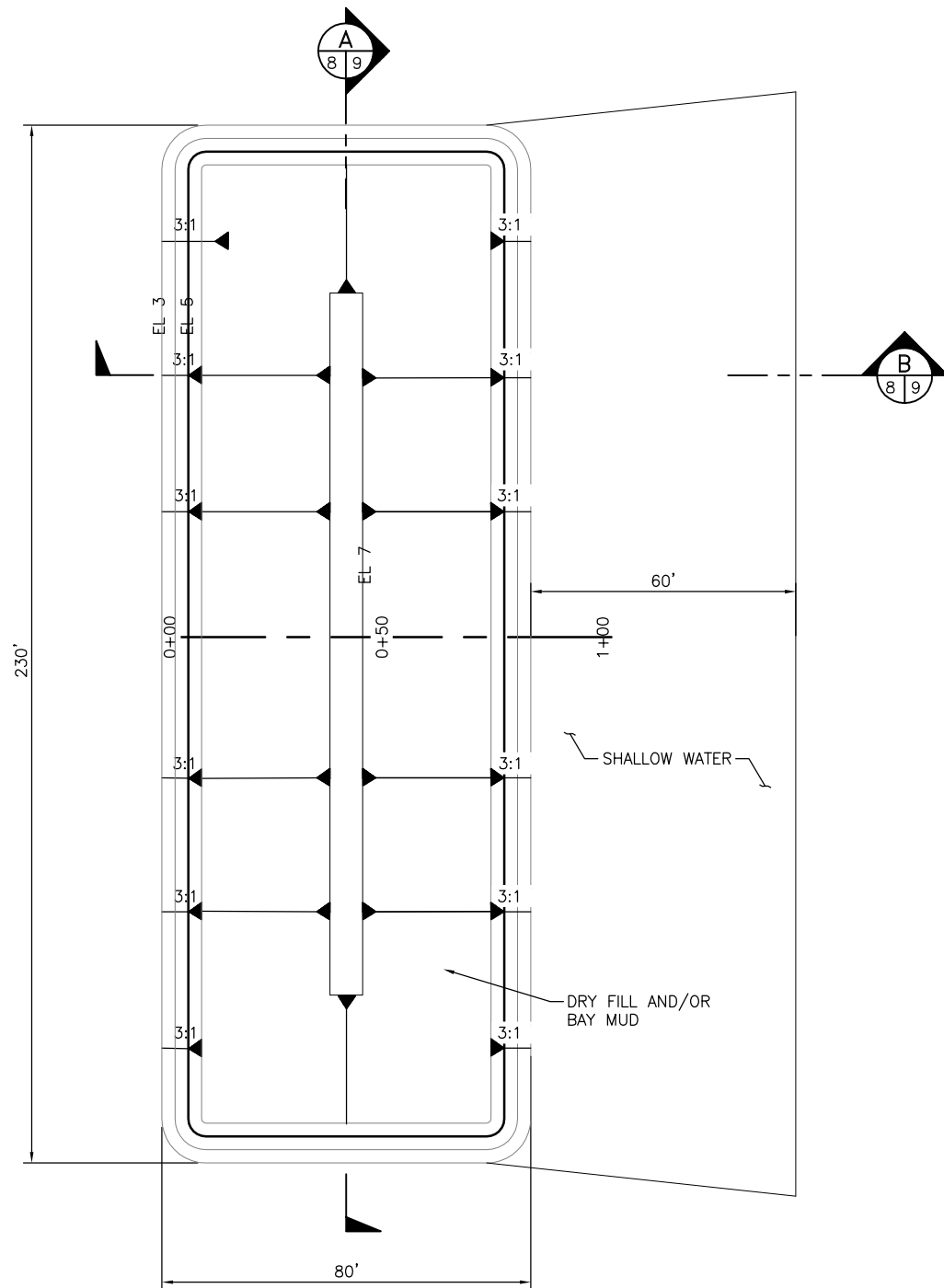

1
 LINEAR NESTING ISLAND PLAN
 STAGE I

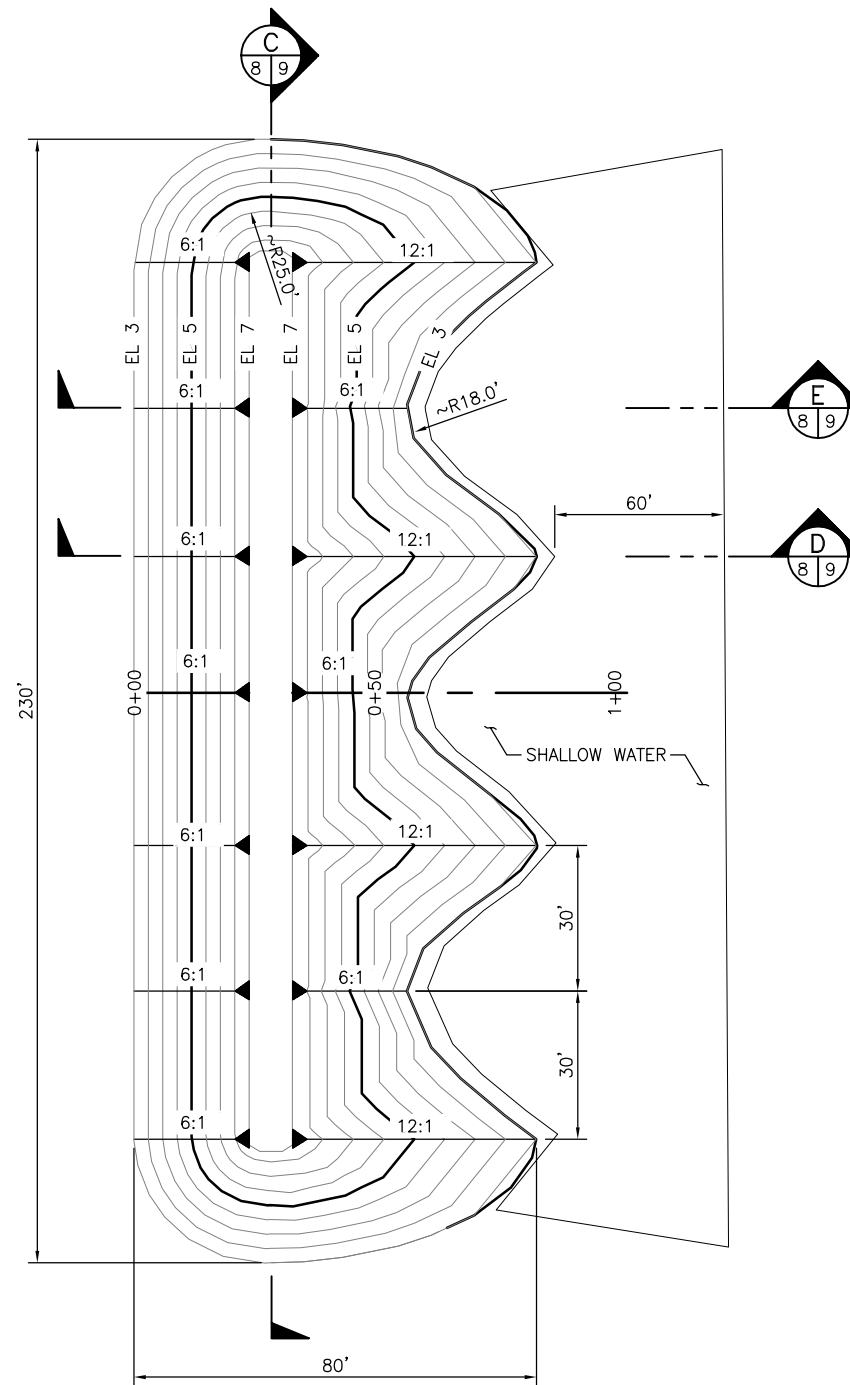
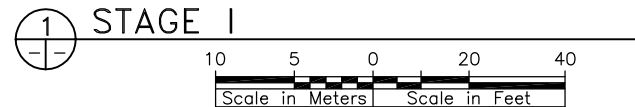

2
 LINEAR NESTING ISLAND PLAN
 STAGE II

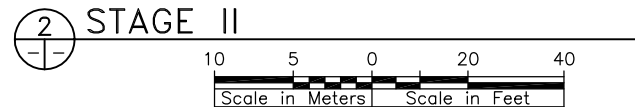

DESIGN PERMIT DRAWINGS

McMILLEN, LLC

1401 SHORELINE DR.
 STE 100
 BOISE, ID 83702
 OFFICE: 208.342.4214
 FAX: 208.342.4216

VERIFY SCALE
 THIS BAR IS
 ONE INCH ON
 ORIGINAL DRAWING
 0" = 1"
 ADJUST SCALES
 ACCORDINGLY, IF
 NOT ONE INCH
 ON THIS SHEET

REV.	DATE	DESCRIPTION	BY

DON EDWARDS SAN FRANCISCO BAY NWR
 POND A16-A17 RESTORATION
 LINEAR NESTING ISLANDS PLAN

DESIGNED GA DRAWN RW CHECKED MM DATE 9/9/11 DRAWING NO. 8R-CA-898-182-8.0

SHEET
 8

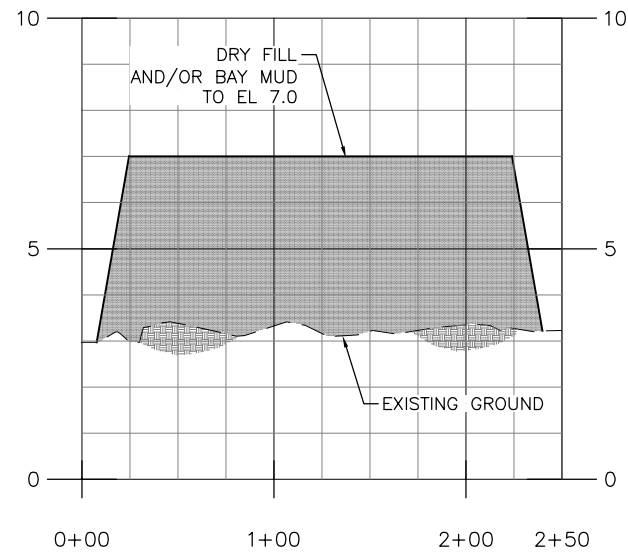

TYPICAL LINEAR NESTING ISLAND PLAN STAGE I
 (A)
 8/9

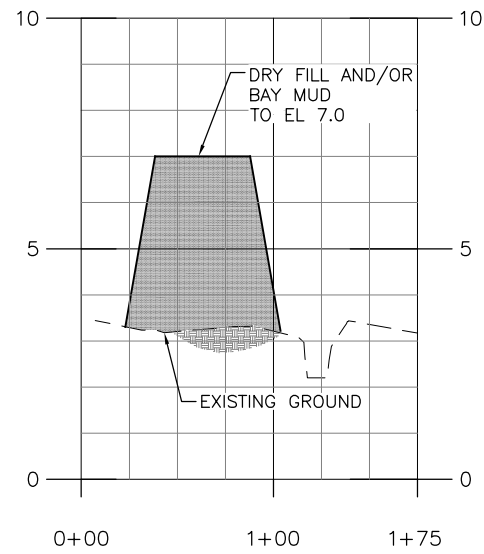

TYPICAL LINEAR NESTING ISLAND PLAN STAGE I
 (B)
 8/9

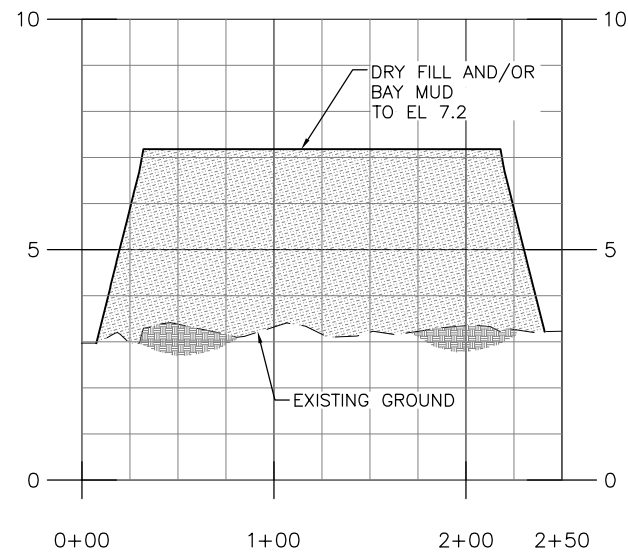

TYPICAL LINEAR NESTING ISLAND PLAN STAGE II
 (C)
 8/9

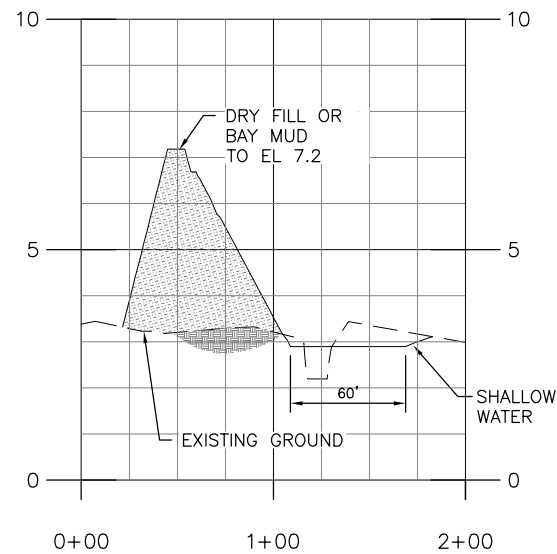

TYPICAL LINEAR NESTING ISLAND PLAN STAGE II
 (D)
 8/9

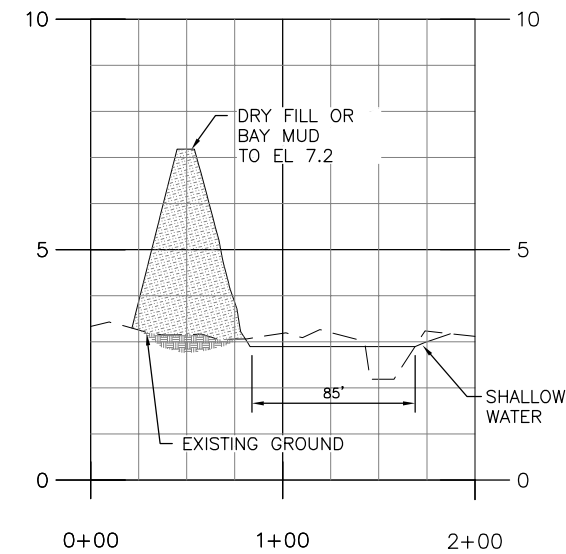

TYPICAL LINEAR NESTING ISLAND PLAN STAGE II
 (E)
 8/9

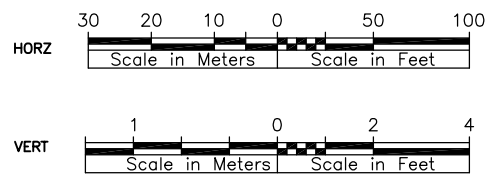

DESIGN PERMIT DRAWINGS
McMILLEN, LLC
 1401 SHORELINE DR.
 STE 100
 BOISE, ID 83702
 OFFICE: 208.342.4214
 FAX: 208.342.4216

VERIFY SCALE
 THIS BAR IS ONE INCH ON ORIGINAL DRAWING
 0" = 1"
 ADJUST SCALES ACCORDINGLY, IF NOT ONE INCH ON THIS SHEET

REV.	DATE	DESCRIPTION	BY

DON EDWARDS SAN FRANCISCO BAY NWR
POND A16-A17 RESTORATION ISLAND L-1 CROSS SECTIONS
 SHEET 9
 DESIGNED DA DRAWN RW CHECKED CB DATE 9/9/11 DRAWING NO. 8R-CA-898-182-9.0